



SRT Removal Tool



Parts ID Manual

Revision: B

© Copyright 2023 by DEMTECH Services, Inc.

All Rights Reserved

Scope of Manual:

This manual contains procedures for safety, general unpacking, set-up, and operation of your DEMTECH Services, Inc. SRT Removal Tool.

The text of this publication, or any part thereof, may not be reproduced or transmitted in any form or by any means, electronic or mechanical, including photocopying, recording, storage in an information retrieval system, or otherwise, without prior written permission of DEMTECH Services, Inc.

Notice

Patents have been granted and/or patent applications are pending or are in the process of preparation on all DEMTECH Services, Inc. developments.

The material in the manual is for informational purposes only and is subject to change without notice.

DEMTECH Services, Inc. assumes no responsibility for any errors that may appear in this manual.

Manual Number: **SRT-PARTS ID MANUAL, Revision: A**

DEMTECH Services, Inc.
6414 Capitol Avenue Diamond Springs, CA 95619 U.S.A.
Telephone: (530) 621-3200
Toll Free: (888) 324-9353
Fax: (530) 621-0150
Web Site: www.demtech.com

TABLE OF CONTENTS

1	ORDER INSTRUCTIONS.....	PAGE 1
1.1	SRT-0200/A – ASSY, STUD REMOVAL TOOL (Parts ID).....	Page 2
1.2	SRT-0200/A – ASSY, STUD REMOVAL TOOL (Parts List).....	Page 3

1 Order Instructions

Refer to the diagrams and related parts lists on the following pages to identify replacement parts for the SRT Removal Tool. To locate a part, find it visually on the exploded assembly diagram and note its Reference Number. Next refer to the assemblies parts list to identify the corresponding Part Number using the Reference Number. When ordering parts, be sure to specify the Part Number not the Reference Number. *'NS-Hardware'* refers to non-stock items, these parts are still available for order, please provide the part description to order NS-Hardware items.

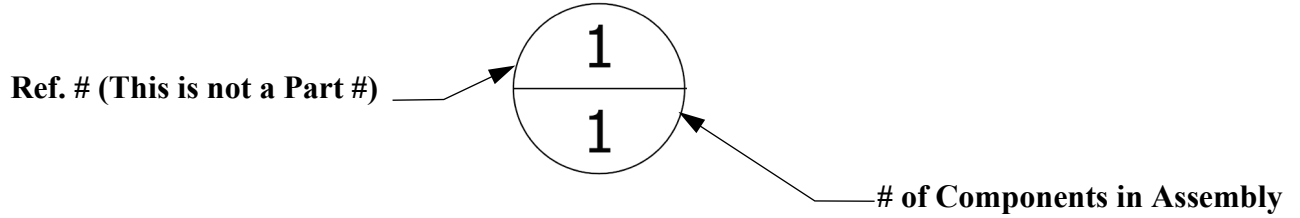

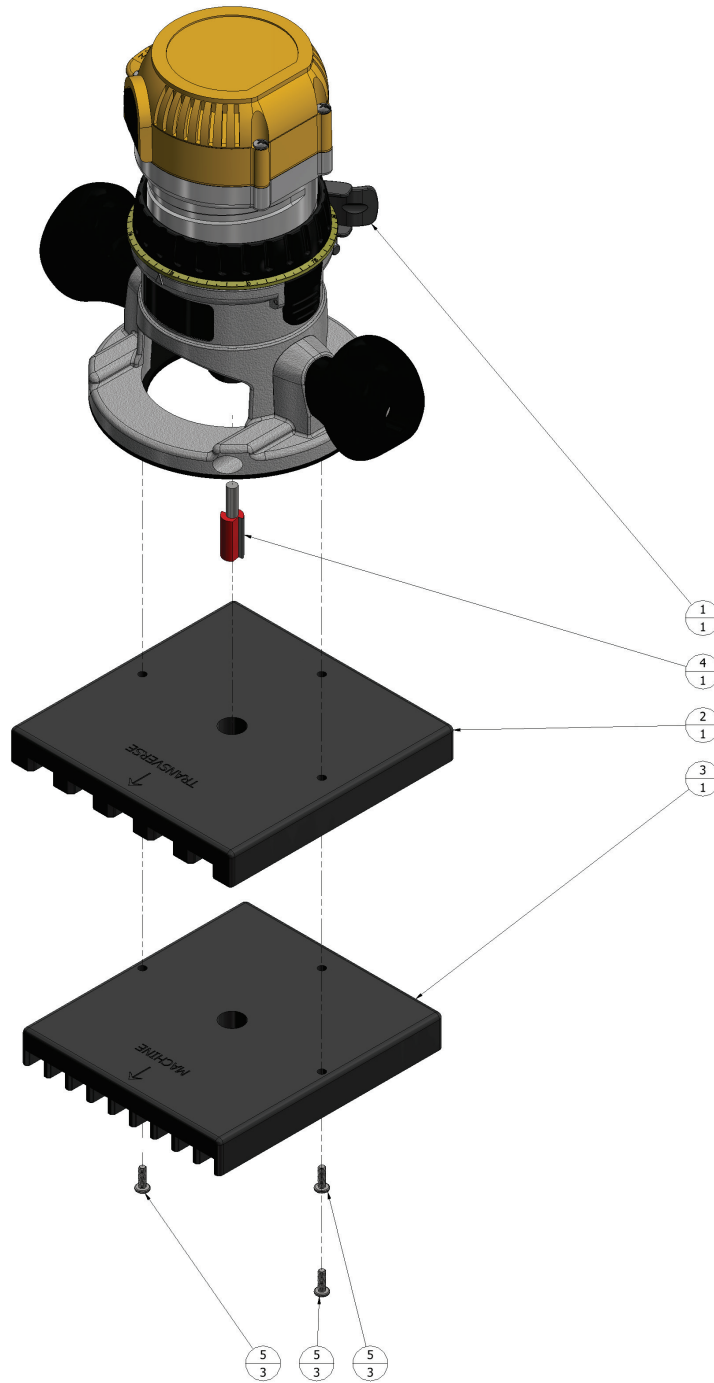

1.1 SRT-0200/A – ASSY, STUD REMOVAL TOOL (Parts ID)

PARTS LIST			
REF. NO	PART NO	DESCRIPTION	QTY
1	SRT-015	ROUTER, STUD REMOVAL TOOL	1
2	SRT-030	ATTACHMENT, STUD REMOVAL TOOL, TRANSVERSE DIRECTION	1
3	SRT-035	ATTACHMENT, STUD REMOVAL TOOL, MACHINE DIRECTION	1
4	SRT-045	BIT, ROUTER, MORTISING, 5/8", STUD REMOVAL TOOL	1
5	NS-HARDWARE	SCREW, PHILLIPS, PAN HEAD, STAINLESS, 8-32-1/2"	3

1.2 SRT-0200/A – ASSY, STUD REMOVAL TOOL (Parts List)