

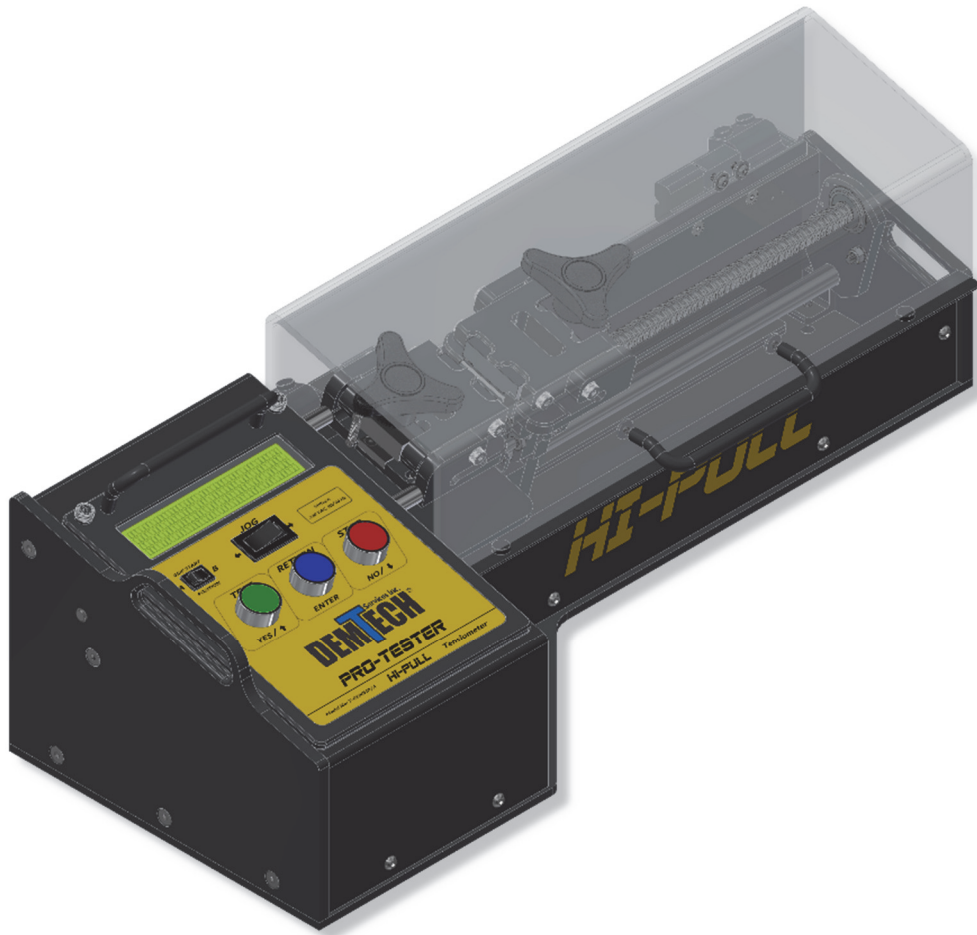

# Pro-Tester Hi-Pull



## Pro-Tester HP Operator's Manual

Model Number: T-0100HP/A

Revision: A

© Copyright 2020 by DEMTECH Services, Inc.

**All Rights Reserved**

**Scope of Manual:**

This manual contains procedures for safety, general unpacking, set-up, and operation of your DEMTECH Services, Inc. Pro-Tester Hi-Pull™ Field Tensiometer.

The text of this publication, or any part thereof, may not be reproduced or transmitted in any form or by any means, electronic or mechanical, including photocopying, recording, storage in an information retrieval system, or otherwise, without prior written permission of DEMTECH Services, Inc.

*Notice*

Patents have been granted and/or patent applications are pending or are in the process of preparation on all DEMTECH Services, Inc. developments.

The material in the manual is for informational purposes only and is subject to change without notice.

DEMTECH Services, Inc. assumes no responsibility for any errors that may appear in this manual.

Manual Number: **T-OPERATOR'S MANUAL/PRO-TESTER HP, Revision: A**

DEMTECH Services, Inc.  
6414 Capitol Avenue Diamond Springs, CA 95619 U.S.A.  
Telephone: (530) 621-3200  
Toll Free: (888) 324-9353  
Fax: (530) 621-0150  
Web Site: [www.demtech.com](http://www.demtech.com)

## Table of Contents

<b>1</b>	<b>SAFETY PRECAUTIONS.....</b>	<b>PAGE 1</b>
<b>2</b>	<b>GENERAL SAFETY &amp; MAINTENANCE INFORMATION.....</b>	<b>PAGE 2</b>
	2.1 Intended Use.....	Page 2
	2.2 Maintenance.....	Page 2
<b>3</b>	<b>GENERAL PRODUCT DATA.....</b>	<b>PAGE 3</b>
<b>4</b>	<b>SITE PREPARATION.....</b>	<b>PAGE 4</b>
<b>5</b>	<b>UNPACKING &amp; INSTALLATION INSTRUCTIONS.....</b>	<b>PAGE 4</b>
	5.1 Unpacking and Preparation.....	Page 5
	5.2 Electrical Plug Connection.....	Page 5
	5.3 Control Panel.....	Page 7
	5.4 Loading Samples.....	Page 9
	5.5 Settings.....	Page 10
	5.6 Elongation Definition.....	Page 10
<b>6</b>	<b>FACTORY SERVICING.....</b>	<b>PAGE 13</b>
<b>7</b>	<b>USER INTERFACE MENU TREE.....</b>	<b>PAGE 13</b>
<b>8</b>	<b>SYSTEM WIRING DIAGRAM.....</b>	<b>PAGE 14</b>
<b>9</b>	<b>PRO-TESTER HI-PULL™ WARRANTY.....</b>	<b>PAGE 14</b>

## 1 Safety Precautions

Safety precautions for operating personnel and equipment:

**WARNING 1:** Operating personnel should perform only the procedures described and recommended in this manual. Only qualified service personnel familiar with electrical shock hazards and mechanical entanglement hazards present inside the equipment should perform disassembly or corrective maintenance of the equipment.

**WARNING 2:** To avoid shock hazards, the equipment must be grounded with an adequate earth ground in accordance with local and national electrical codes.

**WARNING 3:** The locations of potentially dangerous voltages and other hazards are identified and labeled on the equipment. Be careful to observe these warnings when installing, operating, maintaining or servicing the equipment. Observe all warnings in this manual.

**WARNING 4:** Make sure to turn off the equipment power and remove the ~ (AC) line cord from the power outlet before attempting to service the equipment. Do not perform service unless you are qualified and trained to do so.

**WARNING 5:** This product is intended for operator attended operation only. This product should never be left unattended at any time while it is plugged in and the power is turned on. Incorrect use of the product such as overheating of the material can present a fire and explosion hazard, especially near combustible materials and explosive gases.

**WARNING 6:** This product is intended for operation in dry environments only. Higher humidity environments should be kept non-condensing by avoiding large temperature swings.

**WARNING 7:** Do not touch the main housing, air nozzle and/or output molten material when they are hot as they can cause burns. After use allow sufficient time for the product to cool to room temperature before handling and stowing. Do not point or direct the hot air flow and the output molten material in the direction of personnel.

**CAUTION 1:** Observe the precautions given on the equipment and within this manual to prevent damage to the equipment.

**CAUTION 2:** Before connecting the equipment to its electrical power source, check that the ~ (AC) voltage, frequency and current to be supplied to the equipment are correct and match the serial plate affixed to the system.

**CAUTION 3:** Use proper handling and packaging procedures for Electro-Static Discharge (ESD) sensitive Printed Circuit Boards (PCB's). Assume that all PCB's are sensitive to potential damage from ESD.

**CAUTION 4:** Unauthorized personnel should not remove from the equipment those panels or covers that are provided for protection and/or require a tool to remove.

## 2 General Safety & Maintenance Information

The DEMTECH Services, Inc. Pro-Tester Hi-Pull™ field tensiometer, hereinafter referred to as the Pro-Tester™ HP, Pro-Tester™, or tensiometer is a high voltage piece of equipment. Always disconnect the power source before performing any service and/or maintenance procedures on the tensiometer. Never lift, pull or carry the welder by the power cord or electrical connection. Always maintain slack in any extension cords connected to the tensiometer while in operation to avoid damage to the power connections. At all times while operating the tensiometer keep hands, fingers and other body parts well clear of the rotating screw and grip assemblies.

### 2.1 *Intended Use*

The Pro-Tester Hi-Pull™ is intended as professional use equipment and is not intended for sale to the general public.

The Pro-Tester Hi-Pull™ has been manufactured utilizing the latest technology and current safety standards and regulations. However, improper use or abuse may lead to hazardous conditions for the user or other personnel or cause damage to the tensiometer.

Always keep this manual with the Pro-Tester™ at or near the location where the tensiometer is being used so that it can be referred to quickly and easily.

The technician assigned to operate this tensiometer must have read through and become familiar with this manual, particularly all safety information, before operating the Pro-Tester™.

No changes and/or modifications shall be made to the Pro-Tester™ especially as it relates to safety.

### 2.2 *Maintenance*

Maintenance, inspection and adjustment of the Pro-Tester™ shall only be carried out by qualified personnel. Before removing or installing spare parts or performing other repair operations to the tensiometer, consult DEMTECH Services, Inc. or your authorized DEMTECH service center for advice on proper procedures. This will help insure a safe and successful outcome. Always make sure all screw connections are tight before attempting to operate the welder after maintenance and/or repair procedures. Also make sure all covers, guards, and other safety devices have been fully reinstalled before use.

### 3 General Product Data

The DEMTECH Services, Inc. Pro-Tester Hi-Pull™ Field Tensiometer, hereinafter referred to as the Pro-Tester™, dramatically speeds the field testing of welded seam samples by providing an easy to load grip. This arrangement combined with state-of-the-art electrical and electronics controls and an easy to use User Interface (UI) makes the task of performing field sample tests much more efficient. The highly integrated and automated operation of the Pro-Tester™ eliminates cumbersome setup and speeds up process time while providing a very rugged and reliable system. The one button operation combined with automatic return saves time. The enclosed controller system is easy to maintain. You can be assured the Pro-Tester™ has been built using the highest quality materials available which include Billet Aluminum and ground and hardened steel. DEMTECH Services, Inc. strives to make our systems easy to use and built to last. Just like all other DEMTECH Services, Inc. products, even a first-time user will be productive in minutes. With easy adjustments and a one touch operation, you will be getting test results within minutes of installation.

To operate and navigate the various features of the Pro-Tester™ simply follow the text prompts at the bottom of the Liquid Crystal Display (LCD) screen. Significant development was spent making the system very easy to operate by even a novice operator by simply following the screen prompts.

## 4 Site Preparation

Before proceeding with the unpacking and installation instructions in the following section(s) make sure the work site is prepared and ready to use the Pro-Tester™. ***You should have an adequate power source capable of providing clean Alternating Current (AC) power at 110 or 220 Volts at the rated current.*** Refer to the system serial plate affixed to the rear of the system for the voltage and current requirements of your system. The install area should be clean, dry and free of debris and provide adequate working area to allow efficient and effective use of the system.

Carefully follow the detailed unpacking and installation instructions provided in this manual.

## 5 Unpacking & Installation Instructions

This section contains instructions for the unpacking, placement and installation of the Pro-Tester™. Carefully review the following information, sub-sections and each procedure before beginning unpacking and installation of the system.

The Pro-Tester™ comes complete in a reusable portable shipping/transport container. The system can be operated from within the container or removed and placed onto a work bench or appropriate platform for use. When not in use the Pro-Tester™ should always be stored in the shipping/transport container to protect it from the elements and potential damage.

**Note: The system illustrated in this manual shows ALL available features for the Pro-Tester™, therefore, your system may vary slightly in appearance from that depicted.**

## ***5.1 Unpacking and Preparation***

- a. Before opening the shipping/transport container and unpacking the system, inspect the outside of the container thoroughly for any signs of mishandling or damage during shipping. Report any damage to the shipping carrier immediately and do not proceed with unpacking. Since the shipment is made FOB factory, you should consult your administration concerning claims for shipping damage. Please notify DEMTECH Services, Inc. immediately in writing of any shipping damage.
- b. Unlatch and open the shipping/transport container lid and inspect inside the container and equipment thoroughly for any signs of mishandling or damage during shipping. Report any damage to the shipping carrier immediately and do not proceed with unpacking. Since the shipment is made FOB factory, you should consult your administration concerning claims for shipping damage. Please notify DEMTECH Services, Inc. immediately in writing of any shipping damage.
- c. Make note of the orientation of the equipment and packing foam inserts inside the shipping container to facilitate any repackaging requirements in the future.
- d. To avoid injury and/or damage to the system, be sure to use adequate care when lifting, removing or replacing the system into the shipping/transport container.
- e. You may operate the system from within the shipping/transport container or remove it and place it in an appropriate location suitable for the testing you intend to perform.

## ***5.2 Electrical Plug Connection***

- a. Verify proper operation of the Pro-Tester™ before proceeding with the remainder of the installation. The Pro-Tester™ is equipped with a “soft-start” feature. This feature utilizes a toggle power switch on the rear of the system. Toggle the switch up to turn the system ON. Toggle the switch down to turn the system OFF. This feature provides a built in safety to protect the system during connection to a field generator by automatically turning the power off to the system any time AC power is disconnected either by turning off the generator or unplugging the power cord. Upon startup generators can produce significant power surges which can be harmful to the Pro-Tester™. This soft-start feature eliminates ill effects from this phenomenon. Find the Power Cord included with your system and plug one end into the appropriate connector at the rear of the system (refer to Figure 1). Plug the other end into an electrical outlet supplying the proper ~(AC) power. Toggle the Power Switch to the ON position (refer to Figure 5.1).



- b. The system LCD should light up, go through a self-diagnostic test and then prompt the user to press ENTER to initiate the initialization/calibration sequence. Press ENTER to perform the initialization/calibration procedure. For the proper operation of the Pro-Tester™ do not HALT or skip the procedure.
  
- c. The system will first move the grip head in (left) to find the home position, then out (right) to calibrate travel speed. After a short pause the grip will then move back in (left) and stop at the A or B grip separation position depending on which is selected on the Control Panel. This procedure verifies the Pro-Tester™ is in good working condition. If the system performs as described, you are now ready to operate the system. If the system does not perform any of the functions described above please contact DEMTECH Services, Inc.

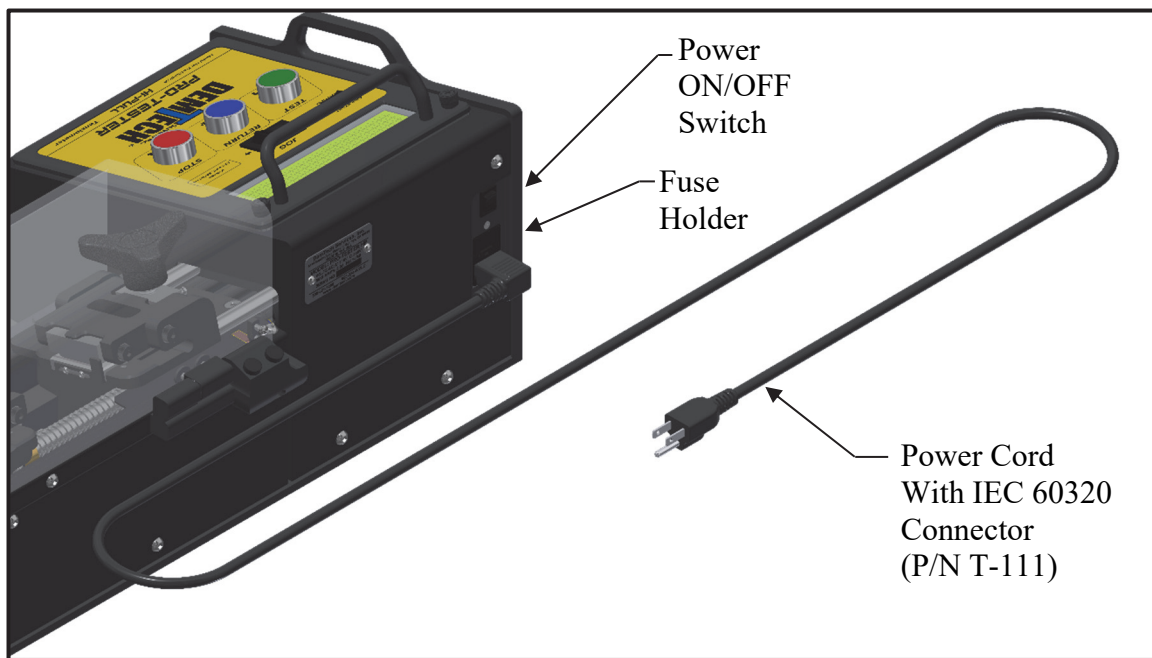

**Figure 5.1**

### 5.3 Control Panel

The User Interface Control Panel is the main operator interface device for operating the Pro-Tester™. Each component of the Control Panel is identified below (refer to Figure 5.3).

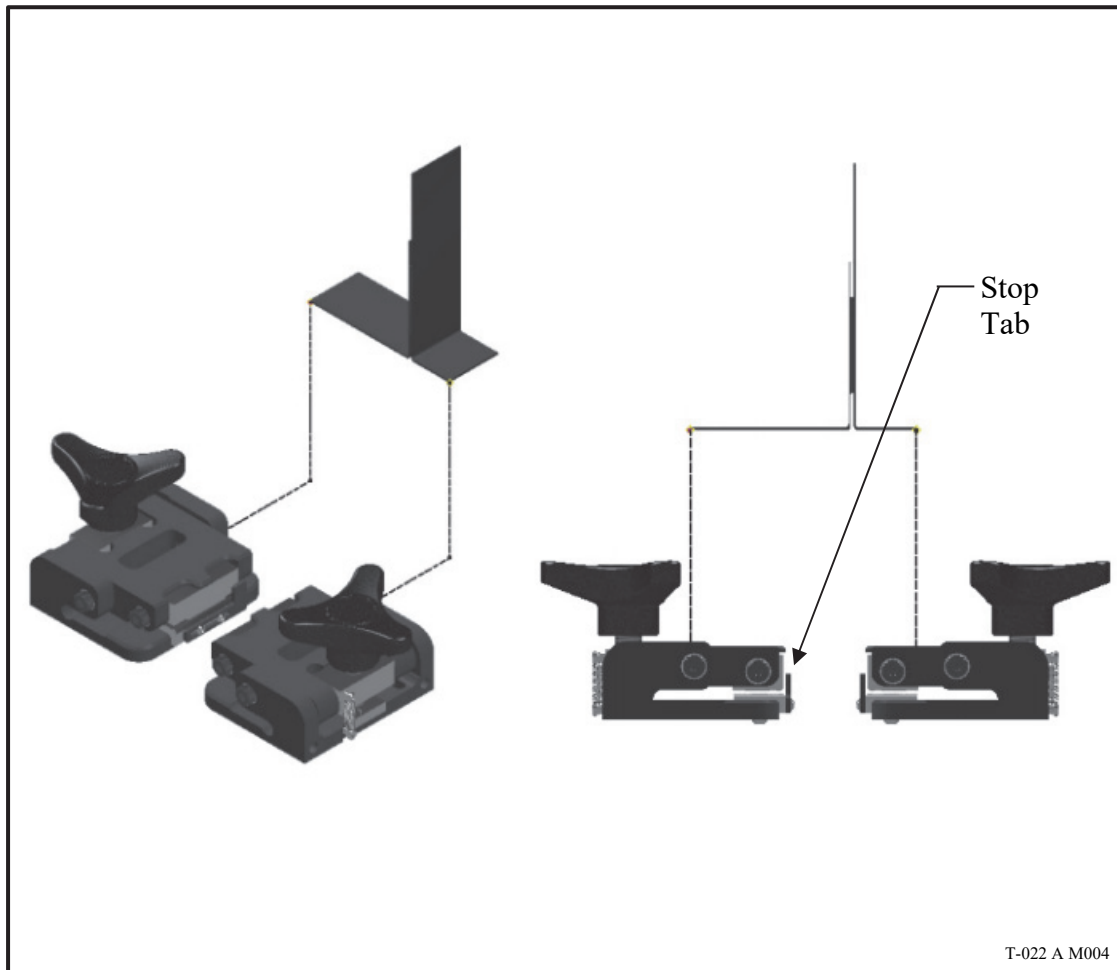

Figure 5.3

- a. Liquid Crystal Display (LCD): The LCD is a 40 Character by 4 Line display device which provides main system operation information for the Control Panel. It provides all key operating information and allows the user to input various system settings.
- b. JOG ⇐/⇒: This switch allows the user to jog (move) the movable sample grip at an accelerated rate in and out during setup and operation of the system and is used to change various settings during Menu Mode operation (refer to Section 6.5).
- c. Grip Start Position Toggle Switch A/B: This switch allows the user to select between one of two grip separation settings. This allows quick transition from one separation length to another. Grip separations A and B can be set through the Menu Mode (refer to Section 6.5).
- d. Test/Yes/⤴: This button is used to initiate a Test or in Menu Mode to navigate the screen tree.
- e. Return Enter: This button is used to return the grips after a test or in Menu Mode to navigate the screen tree.
- f. Stop/No/⤵: This button is used to stop a Test or in Menu Mode to navigate the screen tree.

## 5.4 Loading Samples

Loading samples is very simple with the Pro-Tester™. To load a sample open both jaws of the sample grip assemblies. The left and right grips are both screw clamps and are opened by unscrewing the tri-handle counter-clockwise (open). The sample is prepared by bending the ends to be clamped so they can be easily loaded into the grips. Load the sample from the top of the grip until the sample rests against the stop tabs then apply the left and right grip clamps (refer to Figure 5.4). If loading a 4" (100 mm) test coupon, align the edges of the sample with the edges of the grip frame in order to center the coupon. The stop tabs will need to be removed in order to load a 4" (100 mm) coupon.



**Figure 5.4**

## 5.5 Settings

- a. The Pro-Tester™ requires various settings for proper operation. These settings are easily accessed via the Menu Mode of operation. To enter the Menu Mode, make sure the Pro-Tester™ is on and at the main operating screen (Refer to Page 15). Simultaneously **press and hold the YES and NO** buttons on the Control Panel for several seconds. This procedure puts the system into Menu Mode. This mode of operation allows the user to set various system parameters. For a complete listing of all of the features refer to the diagram on page 15.
- b. All of the settings required to operate the Pro-Tester™ come factory set for most users and should not need setting. However, if your particular installation requires setting any parameters enter the Menu Mode and follow the screen prompts to navigate the screen menu.
- c. Figure 7.1 on page 15 is a Menu Tree drawing. This drawing can be very helpful if you are trying to find a particular function or setting you wish to access. Use the drawing to locate the particular item you want to access. Once located, follow the tree back to the top level. Next, utilizing the user interface on the Pro-Tester™, proceed back down through the menu structure using the drawing as a guide to access the particular screen you want.

## 5.6 Elongation Definition

If you intend to use the strain (elongation) feature of the Pro-Tester™ tensiometer it is important to understand both the definition of this feature/function and how it is intended to be used. Proper understanding requires the definition of some basic terms. These terms are defined below.

- a. **Grip Separation (GS):** The distance between the grip point on each of the left and right sample grip assemblies (refer to Figure 5.5). There are two user settable distances, A or B, which have been factory set for 1.7 and 3.5 inches respectively. The operator must be aware of these values and change the settings if necessary (refer to Section 5.5) to accommodate the particular sample to be tested.
- b. **Weld Extrusion (Squeeze-out):** The area of a weld whereupon becoming molten the parent material extrudes (is squeezed) out from between the pressure zone of the welding tool and then cools. This extruded material does not usually provide an acceptable bond of the parent material and should not be considered part of the weld (refer to Figure 6C).

- c. **Weld Width (WW):** The center-to-center distance between the two welds of a dual-track weld (refer to Figure 6A) or the edge-to-edge distance on a solid weld (refer to Figure 6B). It is important when measuring/calculating these distances that the operator only include the actual width of the weld. The width of the weld is defined as only that area where the two sheets of parent material have been appropriately bonded by both heat and pressure. During this process some parent material may extrude beyond the pressure zone of the welding tool (refer to Weld Extrusion definition). This extruded material does not usually provide an acceptable bond of the parent material and should therefore be excluded from any measurements made for this test.
- d. **Gauge Length (GL):** This is the base value used by the Pro-Tester™ for determining elongation percentage. It is the Grip Separation once the initial tension value has been reached minus the Weld Width ( $GS - WW = GL$ ). For example if your Grip Separation was 4 inches and your Weld Width was 1 1/2 inches then your Gauge Length would be 2 1/2 inches ( $4 - 1.5 = 2.5$ ). It is this value that is used to determine elongation. Elongation is calculated as the percentage of change (increase) of the Grip Separation related to Gauge Length. For example if your Gauge Length is 2 1/2 inches and the grips had separated 1 1/4 inches at the completion of your test then the elongation would be 50% ( $1.25 / 2.5 = .50$ ). If your Gauge Length is 2 1/2 inches and the grips had separated 2 1/2 inches at the completion of your test then the elongation would be 100% ( $2.5 / 2.5 = 1.00$ ).

It is on this basis that the Pro-Tester™ has been designed and programmed to operate when performing elongation testing.

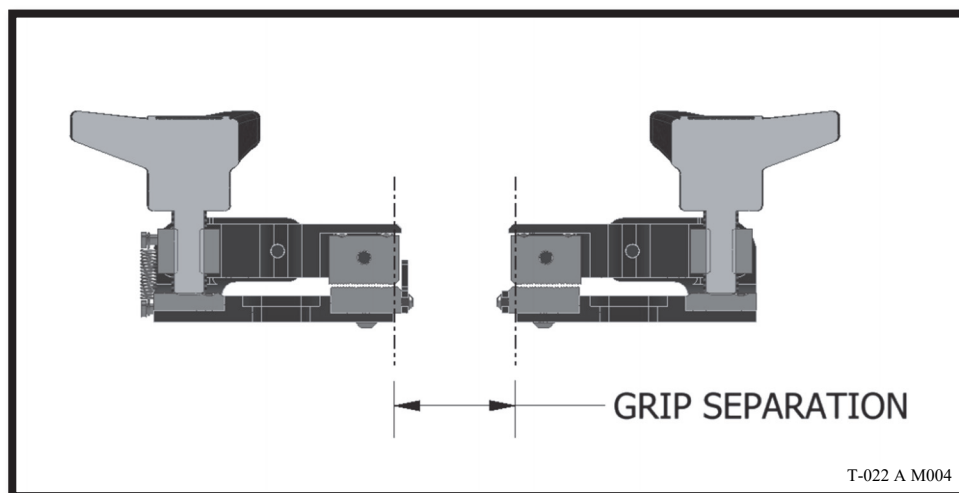

**Figure 5.5**

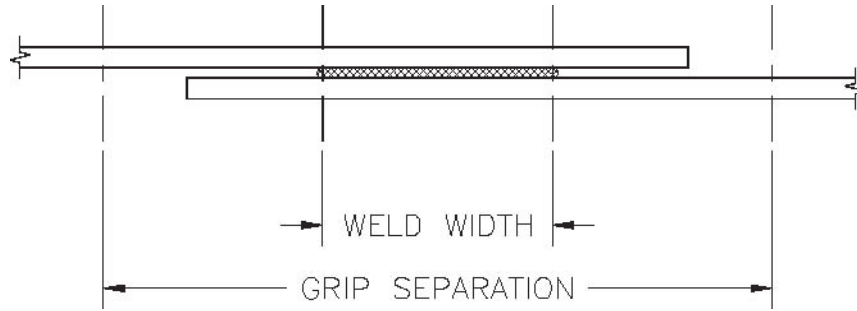

**Figure 6A**

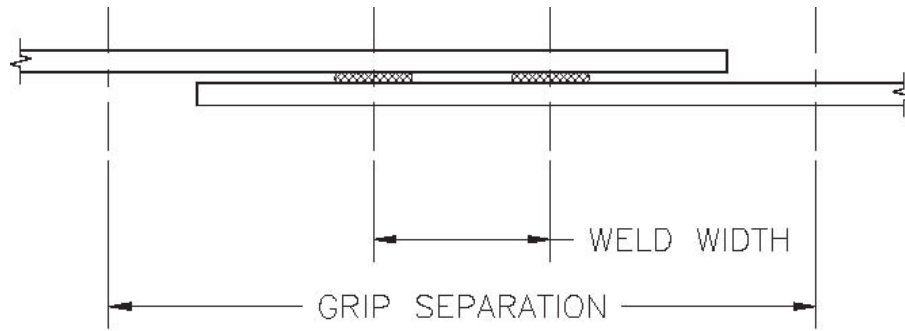

**Figure 6B**

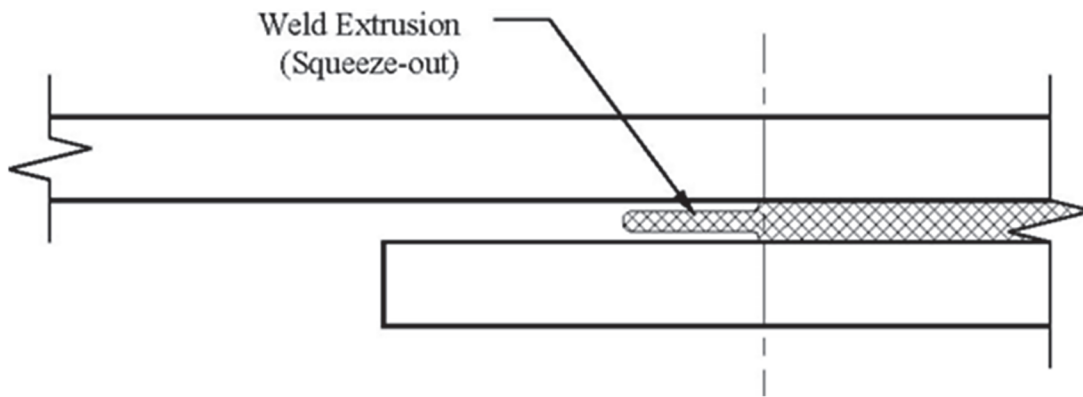

**Figure 6C**

**Figure 6**

## 6 Factory Servicing

In the event your Pro-Tester Hi-Pull™ should require factory service, the entire welder needs to be returned to the factory. Refer to the following step for preparing the Pro-Tester Hi-Pull™ for return.

Carefully pack the Pro-Tester Hi-Pull™ in the reusable portable shipping/storage case provided with the welder for return to DEMTECH Services, Inc.'s factory for service. Unless previous arrangements are made, shipping charges and insurance are the responsibility of the customer. Ship the packaged Pro-Tester Hi-Pull™ to DEMTECH Services, Inc. at:

**DemTech Services, Inc**  
**Ship to address: 6414 Capitol Avenue**  
**Diamond Springs, CA 95619**  
**U.S.A.**

## 7 User Interface Menu Tree

Refer to Page 15 for the Pro-Tester Hi-Pull™ Menu Tree drawing. This drawing can be very helpful if you are trying to find a particular function or setting you wish to access. Use the drawing to locate the particular item you want to access. Once located, follow the tree back to the top level. Next, utilizing the user interface on the Pro-Tester™, proceed back down through the menu structure using the drawing as a guide to access the particular screen you want. To enter the Menu Mode make sure the Pro-Tester™ is on and at the main operating screen (Refer to Page 15). **Simultaneously press and hold the YES and No buttons on the Control Panel for several seconds.**



## 8 System Wiring Diagram

Refer to Page 16 for the Pro-Tester™ System Wire Diagram. This drawing can be very helpful in identifying and/or troubleshooting basic wiring or interconnection issues related to the Pro-Tester™.

## 9 Pro-Tester Hi-Pull™ Warranty

See page 17 for the DEMTECH Services, Inc. product warranty.

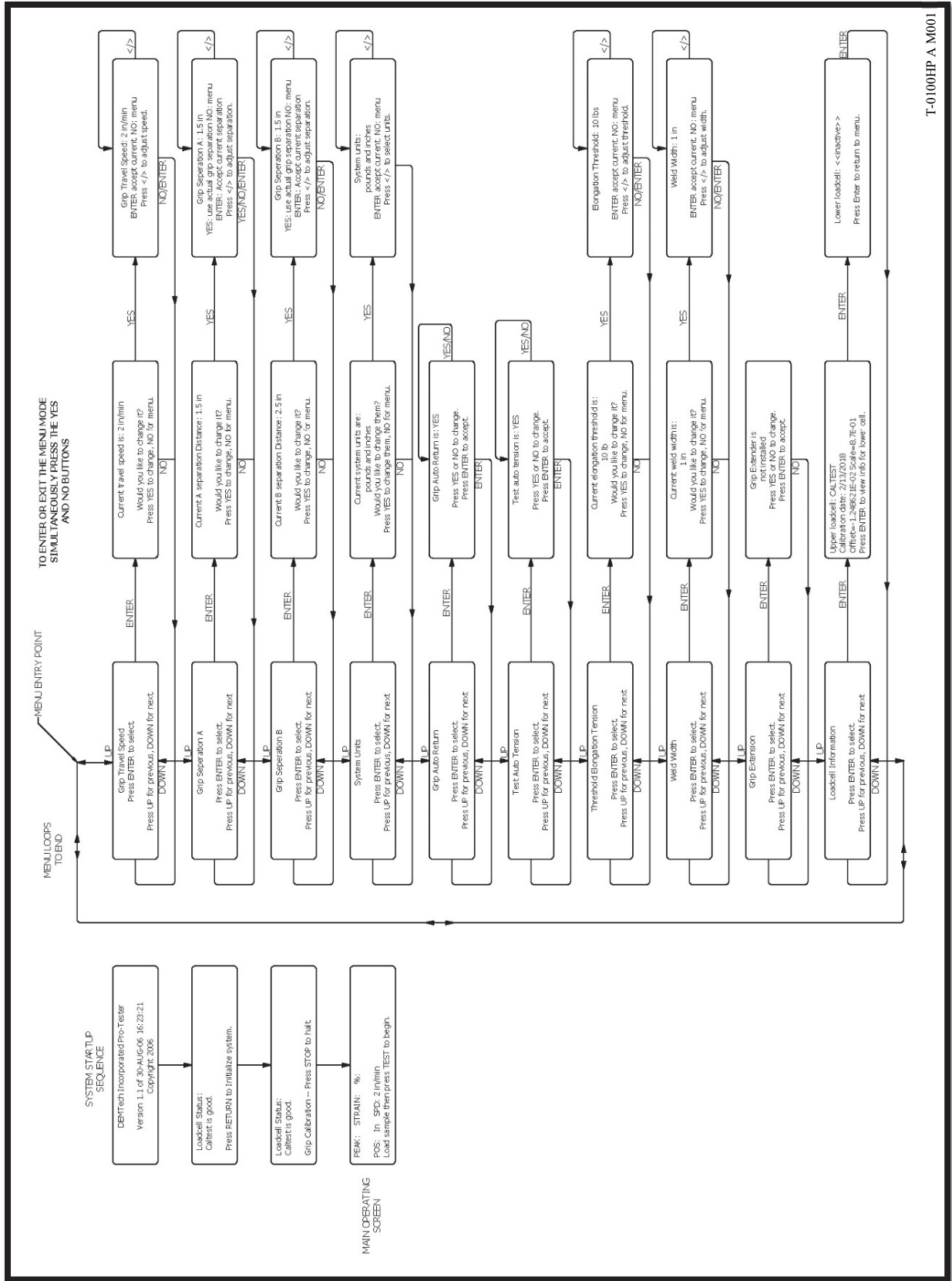

T-0100HP A M001

Figure 7.1



## Warranty

DEMTECH Services, Inc. warrants all equipment of its manufacture to be free from defects in materials, workmanship, mechanical parts, and labor for a period of one year from the date of shipment to the original buyer and ninety days for electrical. This warranty excludes normal wear items such as gears, bearings and chains. The liability under this warranty is limited to replacement parts and labor on equipment when the equipment is returned prepaid to the factory or its authorized service center with prior authorization from DEMTECH Services, Inc., and upon examination by DEMTECH Services, Inc., is determined to be defective. At DEMTECH Services, Inc.'s option, a service representative may be dispatched to the equipment location.

As an additional protection, DEMTECH Services, Inc. warrants that for a period of 90 days from the date of shipment to the original buyer, pending prior authorization from DEMTECH Services, Inc., there will be no charge for service related shipping of parts and/or equipment or for authorized travel of a service representative to the equipment location. After 90 days, all costs incurred for shipping the equipment or parts thereof or for travel are the responsibility of the buyer. Our warranty for this equipment is rendered void if the unit has been repaired, taken apart or modified, or attempted to be, unless such actions have been taken in accordance with written instructions received from DEMTECH Services, Inc. The warranty is also void if the equipment has been subjected to abuse, accident or other abnormal conditions.

### IF ANY FAULT DEVELOPS, THE FOLLOWING STEPS SHOULD BE TAKEN:

1. Notify DEMTECH Services, Inc. by calling 1-888-324-9353. Overseas customers should contact the local DEMTECH authorized service center. Please be prepared with the model number, serial number and full details of the difficulty. Upon receipt of this information, service data or shipping instructions will be provided by DEMTECH Services, Inc. Do not return the unit for repair without first contacting the factory or its representative for instructions.
2. After the initial 90 day period, on receipt of shipping instructions, forward the equipment prepaid to the factory or its authorized service center as instructed. If requested, an estimate of the charges will be made before work begins, especially with those cases where the DEMTECH Services, Inc. product is not covered by the warranty.
3. If the original carton and packing are not available, the product should be packed in a container with a strong exterior and surrounded by a protective layer of shock-absorbing material. DEMTECH Services, Inc. advises returning the equipment at full value to the carrier.

DEMTECH Services, Inc. reserves the right to make changes in design at any time without incurring any obligation to install the same changes on units previously purchased.

This warranty states the essence of the obligations or liabilities on the part of DEMTECH Services, Inc. THE FORMAL, COMPLETE AND EXCLUSIVE STATEMENT OF DEMTECH SERVICES, INC.'S WARRANTY IS CONTAINED IN ITS QUOTATIONS, ACKNOWLEDGEMENTS AND INVOICES. DEMTECH Services, Inc. neither assumes, nor authorizes any person to assume for it, any liability in connection with the sale of its equipment other than those set forth herein.