



## Pro-XMP



## Pro-XMP Parts ID Manual

Model Number: 605-0102/XMP/A

Revision: E

© Copyright 2023 by DEMTECH Services, Inc.

## All Rights Reserved

### Scope of Manual:

This manual contains diagrams and related parts lists to identify potential service/spare parts for your DEMTECH Services, Inc. Pro-XMP Extrusion Welder.

The text of this publication, or any part thereof, may not be reproduced or transmitted in any form or by any means, electronic or mechanical, including photocopying, recording, storage in an information retrieval system, or otherwise, without prior written permission of DEMTECH Services, Inc.

### *Notice*

Patents have been granted and/or patent applications are pending or are in the process of preparation on all DEMTECH Services, Inc. developments.

The material in the manual is for informational purposes only and is subject to change without notice.

DEMTECH Services, Inc. assumes no responsibility for any errors that may appear in this manual.

Manual Number: **605-PARTS ID MANUAL/PRO-XMP, Revision: E**

DEMTECH Services, Inc.  
6414 Capitol Avenue Diamond Springs, CA 95619 U.S.A.  
Telephone: (530) 621-3200  
Toll Free: (888) 324-9353  
Fax: (530) 621-0150  
Web Site: [www.demtech.com](http://www.demtech.com)

## TABLE OF CONTENTS

<b>1</b>	<b>ORDERING INSTRUCTIONS.....</b>	<b>4</b>
1.1	605-0102/XMPA – ASSY, PRO-XMP EXTRUSION WELDER (Parts ID).....	Page 5
1.2	605-0102/XMP/A – ASSY, PRO-XMP EXTRUSION WELDER (Parts List).....	Page 6
1.3	605-0102/XMP/A – ASSY, PRO-XMP EXTRUSION WELDER (Parts List) Contd. ....	Page 7
1.4	600-100/X5/A – ASSY, CONTROLLER, PRO-XMP (Parts ID).....	Page 8
1.5	600-100/X5/A – ASSY, CONTROLLER PRO-XMP (Parts List).....	Page 9
1.6	605-DRILL/XMP/A – ASSY, MOTOR, DRILL, MODIFIED (Parts ID).....	Page 10
1.7	605-DRILL/XMP/A - ASSY, MOTOR, DRILL, MODIFIED (Parts List).....	Page 11

## 1 Ordering Instructions

Refer to the diagrams and related parts lists on the following pages to identify potential service/spare parts for the Pro-XMP Extrusion Welder. To locate a part, find it visually on the exploded assembly diagram and note its Item Number. The Item Number is the upper digit in the item identification balloon. The lower digit in the balloon is the quantity used per assembly. Next refer to the accompanying parts list to identify the corresponding DEMTECH Part Number using the Item Number. When ordering parts, be sure to specify the DEMTECH Part Number not the Item Number.

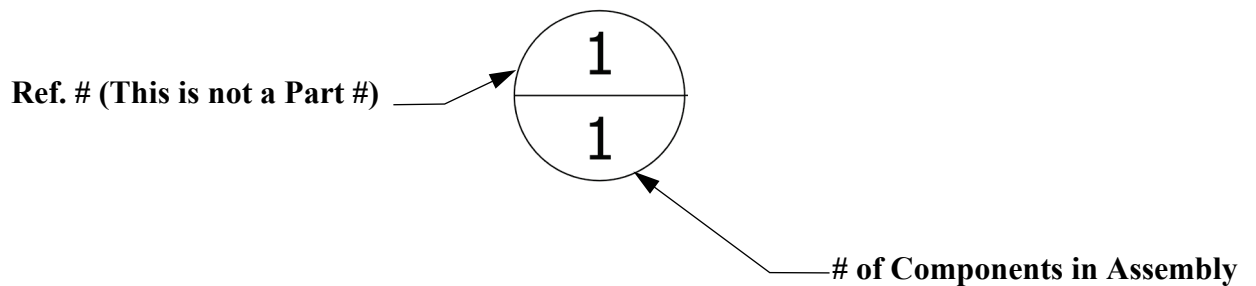

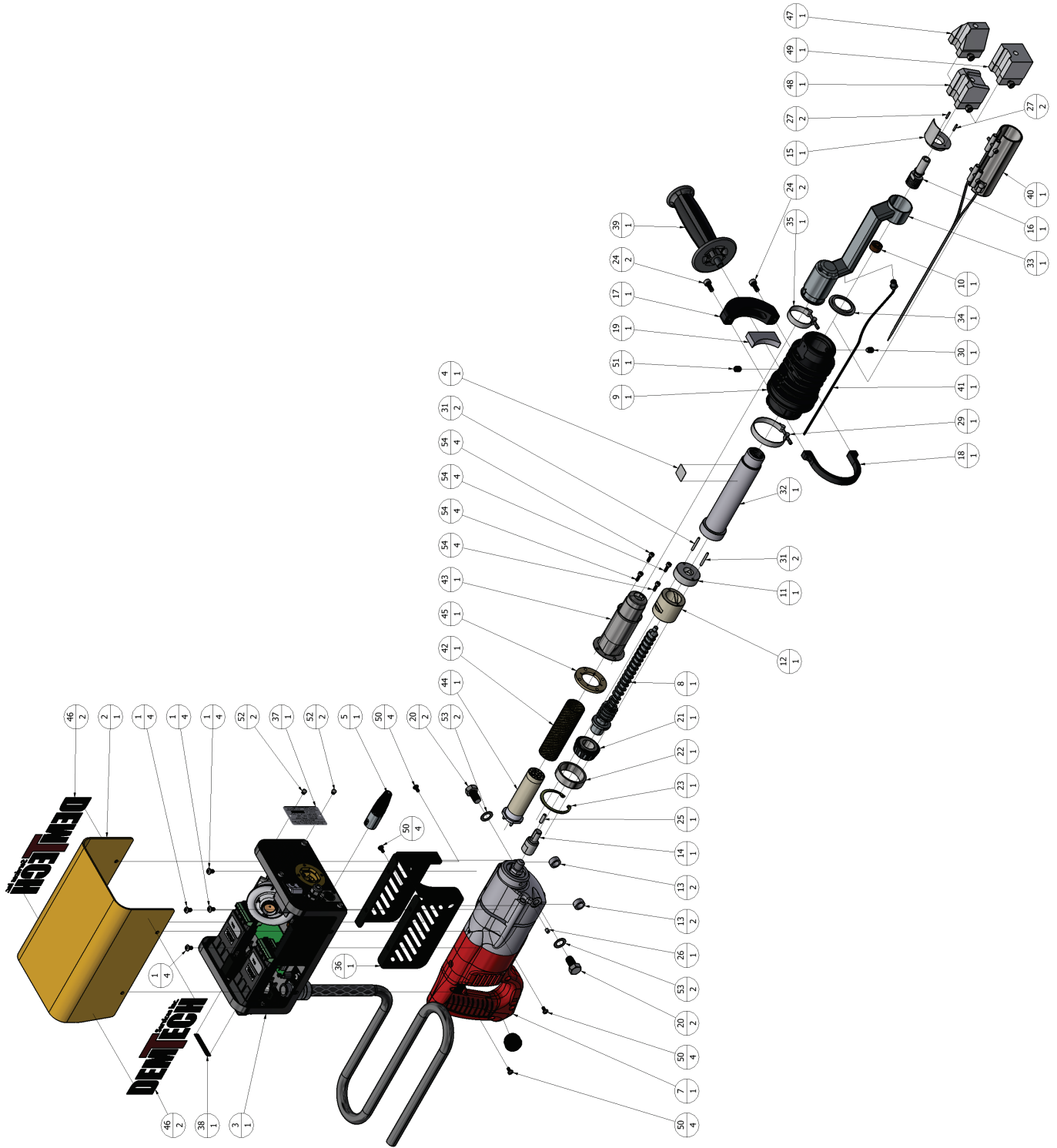

**1.1 605-0102/XMPA – ASSY, PRO-XMP EXTRUSION WELDER  
(Parts ID)**

PARTS LIST			
ITEM	PART NUMBER	DESCRIPTION	QTY
1	110-287	SCREW, M5 X 0.8 X 8mm LONG, BUTTON HEAD SOCKET CAP, 18-8 STAINLESS STEEL	4
2	600-056	COVER, CONTROLLER HOUSING, X5	1
3	600-100/X5/A	ASSEMBLY, CONTROLLER, PRO-X5	1
4	600-23EX.0	ASSEMBLY, THERMOCOUPLE	1
5	600-35EX	PLUG, HEATER BAND	1
6	600-44	PLUG, STANDLE	1
7	605-002	MOTOR, DRILL, MODIFIED	1
8	605-005	SCREW, EXTRUSION	1
9	605-007	HOUSING, BARREL	1
10	605-008	INSERT, MIXING	1
11	605-009	INSERT, WELD ROD CUT	1
12	605-010/PR	INSERT, WELD ROD FEED	1
13	605-011	SPACER, BRACKET SIDE	2
14	605-014	STUD, MOTOR OUTPUT	1
15	605-016	SHIELD, NOZZLE AIR	1
16	605-017	NOZZLE, BARREL OUTPUT	1
17	605-020	BRACKET, GRIP HANDLE	1
18	605-021	CLAMP, GRIP HANDLE	1
19	605-022	GIB, GRIP HANDLE	1
20	605-024	BOLT, 7/16-14 X 3/4" LONG, HEX HEAD CAP, 18-8 STAINLESS STEEL	2
21	605-028	BEARING, TAPERED ROLLER ASSY, 3/4" ID X 1-25/32" OD X 21/32" WIDE	1
22	605-029	RING, OUTER, TAPERED ROLLER, 3/4" ID X 1-25/32" OD X 15/32" WIDE	1
23	605-030	RING, RETAINING, INTERNAL, 1-3/4" HOUSING, ZINC CHROMATE STEEL	1
24	605-031	SCREW, M6 X 1 X 14mm LONG, SOCKET HEAD CAP, 18-8 STAINLESS STEEL	2
25	605-032	PIN, DOWEL, 3/16" OD X 5/8" LONG, HARDENED, 416 STAINLESS STEEL	1
26	605-033	PIN, DOWEL, 3/16" OD X 1/4" LONG, 18-8 STAINLESS STEEL	1
27	605-035	PIN, COILED SPRING, 2.5mm OD X 12mm LONG, STD DUTY, STEEL	2
29	605-040	CLAMP, SCREW, 47.5 - 50mm RANGE, STAINLESS STEEL	1
30	605-041	SCREW, SET, M8 X 1.25 X 10mm LONG, ALLEN SOCKET EXTENDED DOG POINT, 18-8 STAINLESS STEEL	1
31	605-042	PIN, DOWEL, 1/8" OD X 1" LONG, HARDENED, 416 SS	2
32	605-050	BARREL, EXTRUDER	1
33	605-052	MANIFOLD, PRE-HEAT AIR	1
34	605-053	WASHER, PRE-HEAT AIR MANIFOLD	1
35	605-058	CLAMP, SCREW, 30-36mm RANGE, STAINLESS STEEL	1
36	605-064	BRACKET, CONTROLLER HOUSING	1
37	605-399/XMP	PLATE, SERIAL, PRO-XMP	1
38	605-057/XMP	LABEL, PRO-XMP MODEL	1
39	605-D46	HANDLE, DRILL MOTOR	1
40	605-E002	HEATER, BARREL, 600 WATT, 220 VAC	1
41	605-E003	ASSEMBLY, THERMOCOUPLE, TYPE J, PRE-HEAT MANIFOLD	1
42	A-6100297	TUBE, MICA, INSULATION	1
43	A-6100300	SLEEVE, HEAT	1

**1.2 605-0102/XMP/A – ASSY, PRO-XMP EXTRUSION WELDER  
(Parts List)**

PARTS LIST			
ITEM	PART NUMBER	DESCRIPTION	QTY
44	L-100.689	ELEMENT, HEAT, 230V, 1550 WATTS	1
45	L-103.224	RING, FIBER	1
46	LABEL-DEMTECH	LABEL, DEMTECH, LARGE	2
47	TS-605-0500/A	ASSEMBLY, SHOE, CORNER, INSIDE FOR 12mm (1/2") SHEET THICKNESS	1
48	TS-605-60/A	ASSEMBLY, SHOE, OVERLAP FOR 1.0-2.0mm (40-80mil) SHEET THICKNESS	1
49	TS-605-B/A	ASSEMBLY, SHOE, BLANK	1
50	NS-HARDWARE	SCREW, M4 X 0.7 X 8mm LONG, PAN HEAD PHILLIPS, 18-8 STAINLESS STEEL	4
51	NS-HARDWARE	SCREW, SET, M8 X 1.25 X 10mm LONG, ALLEN SOCKET CUP POINT, 18-8 STAINLESS STEEL	1
52	NS-HARDWARE	RIVET, 1/8" BLIND, DOMED HEAD, .063-.125" MATL THICK, 18-8 STAINLESS STEEL	2
53	NS-HARDWARE	WASHER, 7/16" FLAT, .45" ID X .75" OD X .03" THICK, 300 SERIES STAINLESS STEEL	2
54	NS-HARDWARE	SCREW, M4 X 0.7 X 12mm LONG, SOCKET HEAD CAP, 18-8 STAINLESS STEEL	4

***1.3 605-0102/XMP/A – ASSY, PRO-XMP EXTRUSION WELDER  
(Parts List) Contd.***

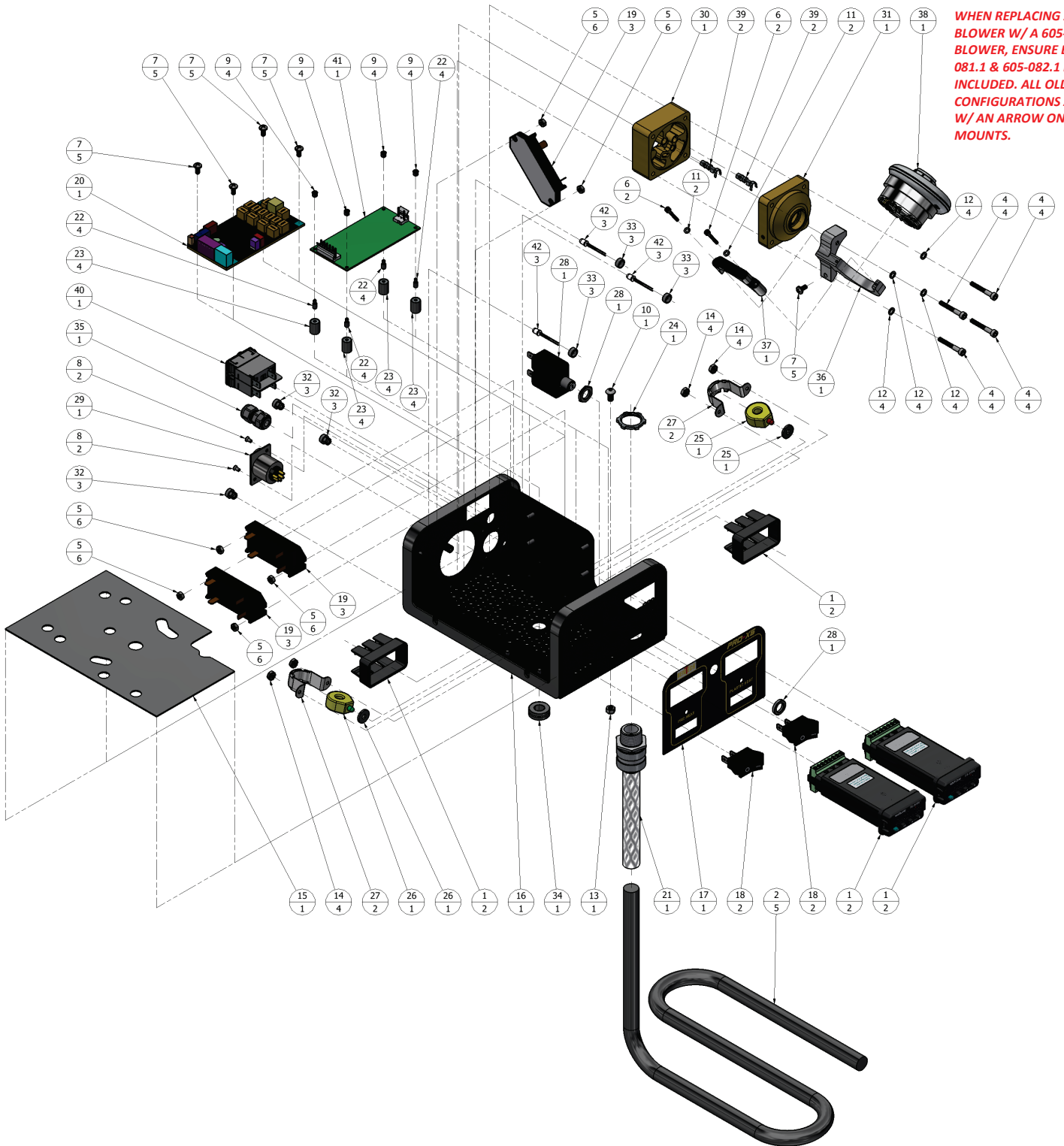

**WHEN REPLACING A 605-E004 BLOWER W/ A 605-E004.1 BLOWER, ENSURE BOTH A 605-081.1 & 605-082.1 MOUNT ARE INCLUDED. ALL OLD BLOWER CONFIGURATIONS ARE ETCHED W/ AN ARROW ON THE MOUNTS.**

**1.4 600-100/X5/A – ASSY, CONTROLLER, PRO-XMP  
(Parts ID)**



PARTS LIST			
REF. NO	PART NO	DESCRIPTION	QTY
1	100-426	CONTROLLER, TEMPERATURE, EZ-ZONE	2
2	100-475	CABLE, POWER CORD	5
3	600-055	HOUSING, CONTROLLER, X5	1
4	600-055.03	SCREW, M4 X 0.7 X 30mm LONG, SOCKET HEAD CAP, 18-8 STAINLESS STEEL	4
5	600-055.04	NUT, M4 X 0.7 HEX, 7mm WIDE X 3.2mm THICK, 18-8 STAINLESS STEEL	6
6	600-055.05	SCREW, M3 X 0.5 X 22mm LONG, SOCKET HEAD CAP, 18-8 STAINLESS STEEL	2
7	600-055.06	SCREW, M4 X 0.7 X 8mm LONG, PAN HEAD PHILLIPS, 18-8 STAINLESS STEEL	5
8	600-055.07	SCREW, M3 X 0.5 X 6mm LONG, FLAT HEAD PHILLIPS, 18-8 STAINLESS STEEL	2
9	600-055.08	NUT, ALLEN, 4-40 X .18" LONG, ALLOY STEEL	4
10	600-055.09	SCREW, M5 X 0.8 X 10mm LONG, BUTTON HEAD SOCKET CAP, 18-8 STAINLESS STEEL	1
11	600-055.10	WASHER, M3 REGULAR SPLIT LOCK, 18-8 STAINLESS STEEL	2
12	600-055.12	WASHER, M4 REGULAR SPLIT LOCK, 18-8 STAINLESS STEEL	4
13	600-055.13	NUT, M5 X 0.8 HEX, NYLON-INSERT LOCKNUT, 18-8 STAINLESS STEEL	1
14	600-055.14	NUT, 6-32 HEX W/ TOOTH WASHER, 5/16" WIDE X 7/64" THICK, 18-8 STAINLESS STEEL	4
15	600-055F	FILTER, CONTROLLER HOUSING, X5	1
16	600-055G	GASKET, CONTROLLER HOUSING, X5	1
17	600-057	OVERLAY, CONTROL PANEL, X5	1
18	600-06	SWITCH, PRE-HEAT / PLASTIC HEAT	2
19	600-060	RELAY, SOLID STATE, 24-280 VAC, DC INPUT, 25 AMP	3
20	600-061	ASSEMBLY, CONTROLLER INTERCONNECT PCB	1
21	600-062	STRAIN RELIEF, 1/2" MNPT STRAIGHT X .50-.63" DIA CORD, ALUMINUM	1
22	600-063	THREAD ADAPTER, 8-32 MALE TO 4-40 MALE, STAINLESS STEEL	4
23	600-064	MOUNT, VIBRATION-DAMPING SANDWICH, 8-32 FEMALE X 8-32 FEMALE	4
24	600-065	NUT, CONDUIT FITTING LOCK, 1/2" NPT, ZINC PLATED STEEL	1
25	600-09	CURRENT INDICATOR, RED	1
26	600-10	CURRENT INDICATOR, GREEN	1
27	600-11	BRACKET, CURRENT INDICATOR	2
28	600-29EX	CIRCUIT BREAKER, 5A	1
29	600-41EX	RECEPTACLE, HEATBAND, 5 PRONG	1
30	605-051	MOUNT, HEATER, INTERNAL	1
31	605-060	HOUSING, BLOWER, INTERNAL	1
32	605-071	CLIP, LED, 5mm, W/ BEZEL	3
33	605-072	SPACER, LED, 5mm	3
34	605-073	GROMMET, 3/4" ID X 1-3/8" OD X 1/16" PANEL THK X 1-1/16" DIA PANEL HOLE, BUNA-N	1
35	605-074	CORDGRIP, LIQUID TIGHT, STRAIGHT-THRU, PG HUB, BLACK	1
36	605-081.1	BRACKET, BLOWER MOUNT, TYPE 2	1
37	605-082.1	CLAMP, BLOWER MOUNT, TYPE 2	1
38	605-E004.1	BLOWER, MINIATURE RADIAL, 70 X 45.7mm, 24 VDC	1
39	605-E007	CONTACT, 4mm DIA, DUAL CRIMP	2
40	605-E009	SWITCH, POWER/BREAKER, DPST, ON/OFF, 15A @ 240 VAC, WHITE OPAQUE	1
41	605-E010	POWER SUPPLY, DUAL OUTPUT, +5VDC @ 3.5A / +24VDC @ 1.5A	1
42	605-E011	LED, HIGH INTENSITY, 5mm, 15 DEGREE VIEWING ANGLE, WHITE	3

**1.5 600-100/X5/A – ASSY, CONTROLLER PRO-XMP  
(Parts List)**

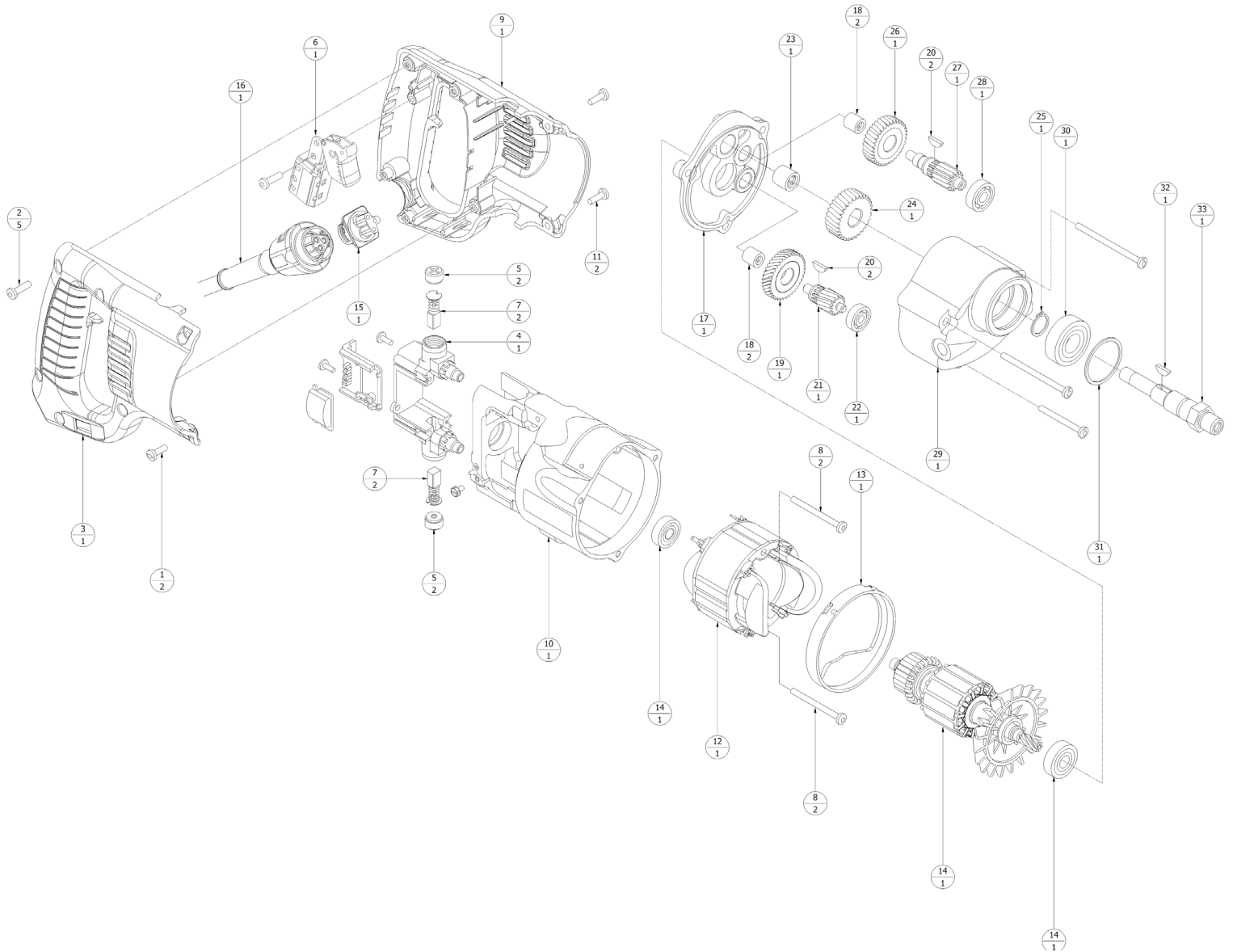

**1.6 605-DRILL/XMP/A – ASSY, MOTOR, DRILL, MODIFIED  
(Parts ID)**

PARTS LIST			
REF. NO	PART NUMBER	DESCRIPTION	QTY
1	605-D01	SCREW, D-HANDLE, 1	2
2	605-D02	SCREW, D-HANDLE, 2	5
3	605-D03	HANDLE, RIGHT SIDE	1
4	605-D05	HOLDER, BRUSH	1
5	605-D06	CAP, RETAINING, CARBON BRUSH	2
6	605-D07	SWITCH, TRIGGER, PRO-XM/XME/XMP, RED	1
7	605-D08	BRUSH, CARBON, DRILL MOTOR	2
8	605-D13	SCREW, FIELD WINDING	2
9	605-D16	HANDLE, LEFT SIDE	1
10	605-D19	HOUSING, MOTOR	1
11	605-D21	NUT, D-HANDLE	2
12	605-D23	FIELD, 220V	1
13	605-D25	BAFFLE, ARMATURE FAN	1
14	605-D26/A	ARMATURE, W/ FAN & BEARINGS, 220V, XM/XME/XMP	1
15	605-D29-2	RECEPTACLE, CORD, 2-CONDUCTOR (XM ONLY), (XME/XMP USE 600-PH CORD)	1
15	605-D29-3	RECEPTACLE, CORD, 3-CONDUCTOR (XM ONLY), (XME/XMP USE 600-PH CORD)	1
16	605-D30-2	CORD, QUIK-LOK, 2-CONDUCTOR (XM ONLY), (XME/XMP USE 600-PH CORD)	1
16	605-D30-3	CORD, QUIK-LOK, 3-CONDUCTOR (XM ONLY), (XME/XMP USE 600-PH CORD)	1
17	605-D33	PLATE, BEARING	1
18	605-D34	BEARING, NEEDLE	2
19	605-D35	GEAR, INTERMEDIATE	1
20	605-D36	KEY, WOODRUFF	1
21	605-D37	SHAFT, INTERMEDIATE	1
22	605-D38	BEARING, BALL	1
23	605-D39	BEARING, NEEDLE	1
24	605-D40	GEAR, SPINDLE	1
25	605-D41	RING, RETAINING	1
26	605-D42	GEAR, INTERMEDIATE 2	1
27	605-D43	SHAFT, INTERMEDIATE 2	1
28	605-D44	BEARING, BALL	1
29	605-D45	CASE, GEAR	1
30	605-D47	BEARING, BALL	1
31	605-D48	RING, RETAINING	1
32	605-D51	KEY, WOODRUFF	1
33	605-D52	SPINDLE, OUTPUT	1

***1.7 605-DRILL/XMP/A - ASSY, MOTOR, DRILL, MODIFIED  
(Parts List)***