



Pro-X5



Pro-X5 Parts ID Manual

Model Number: 600-0105/X5/A

Revision: E

© Copyright 2024 by DEMTECH Services, Inc.

All Rights Reserved

Scope of Manual:

This manual contains diagrams and related parts lists to identify potential service/spare parts for your DEMTECH Services, Inc. Pro-X5 Extrusion Welder.

The text of this publication, or any part thereof, may not be reproduced or transmitted in any form or by any means, electronic or mechanical, including photocopying, recording, storage in an information retrieval system, or otherwise, without prior written permission of DEMTECH Services, Inc.

Notice

Patents have been granted and/or patent applications are pending or are in the process of preparation on all DEMTECH Services, Inc. developments.

The material in the manual is for informational purposes only and is subject to change without notice.

DEMTECH Services, Inc. assumes no responsibility for any errors that may appear in this manual.

Manual Number: **600-PARTS ID MANUAL/PRO-X5, Revision: E**

DEMTECH Services, Inc.
6414 Capitol Avenue Diamond Springs, CA 95619 U.S.A.
Telephone: (530) 621-3200
Toll Free: (888) 324-9353
Fax: (530) 621-0150
Web Site: www.demtech.com

TABLE OF CONTENTS

1	ORDERING INSTRUCTIONS.....	1
1.1	600-0105/A – ASSY, PRO-X5 EXTRUSION WELDER (Parts ID).....	Page 2
1.2	600-0105/A – ASSY, PRO-X5 EXTRUSION WELDER (Parts List).....	Page 3
1.3	600-100/X5/A – ASSY, CONTROLLER, PRO-X5 (Parts ID).....	Page 4
1.4	600-100/X5/A – ASSY, CONTROLLER, PRO-X5 (Parts List).....	Page 5
1.5	600-DRILL/X5/A – ASSY, DRILL MOTOR COMPLETE, PRO-X5 (Parts ID).....	Page 6
1.6	600-DRILL/X5/A – ASSY, DRILL MOTOR COMPLETE, PRO-X5 (Parts List).....	Page 7
1.7	600-D08/X5/A – ASSY, MOTOR HOUSING COMPLETE (Parts ID).....	Page 8
1.8	600-D08/X5/A – ASSY, MOTOR HOUSING COMPLETE (Parts List).....	Page 9
1.9	600-D100A/X5/A - ASSY, GEAR BOX COMPLETE, W/ ARMATURE, CODE: RED, PRO-X5 (Parts ID).....	Page 10
1.10	600-D100A/X5/A - ASSY, GEAR BOX COMPLETE, W/ ARMATURE, CODE: RED, PRO-X5 (Parts List).....	Page 11
1.11	600-D100/X4/A – ASSY, GEARBOX COMPLETE, W/O ARMATURE (Parts ID).....	Page 12
1.12	600-D100/X4/A – ASSY, GEARBOX COMPLETE, W/O ARMATURE (Parts List).....	Page 13

1 Ordering Instructions

Refer to the diagrams and related parts lists on the following pages to identify potential service/spare parts for the Pro-X5. To locate a part, find it visually on the exploded assembly diagram and note its Reference Number. Next refer to the assemblies parts list to identify the corresponding Part Number using the Reference Number. When ordering parts, be sure to specify the Part Number not the Reference Number. *'NS-Hardware'* refers to non-stock items, these parts are still available for order, please provide the part description to order NS-Hardware items.

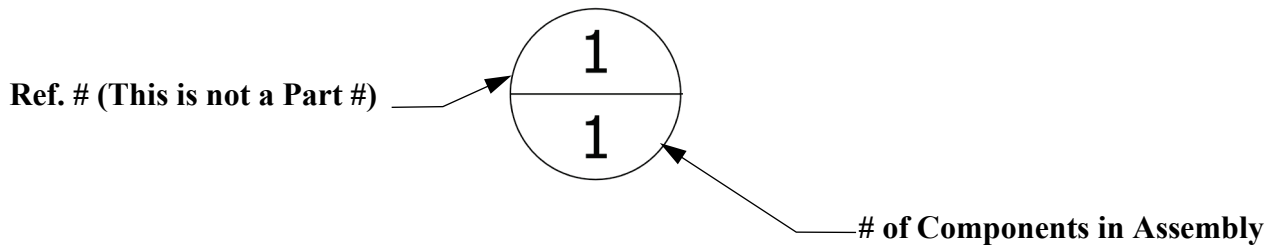

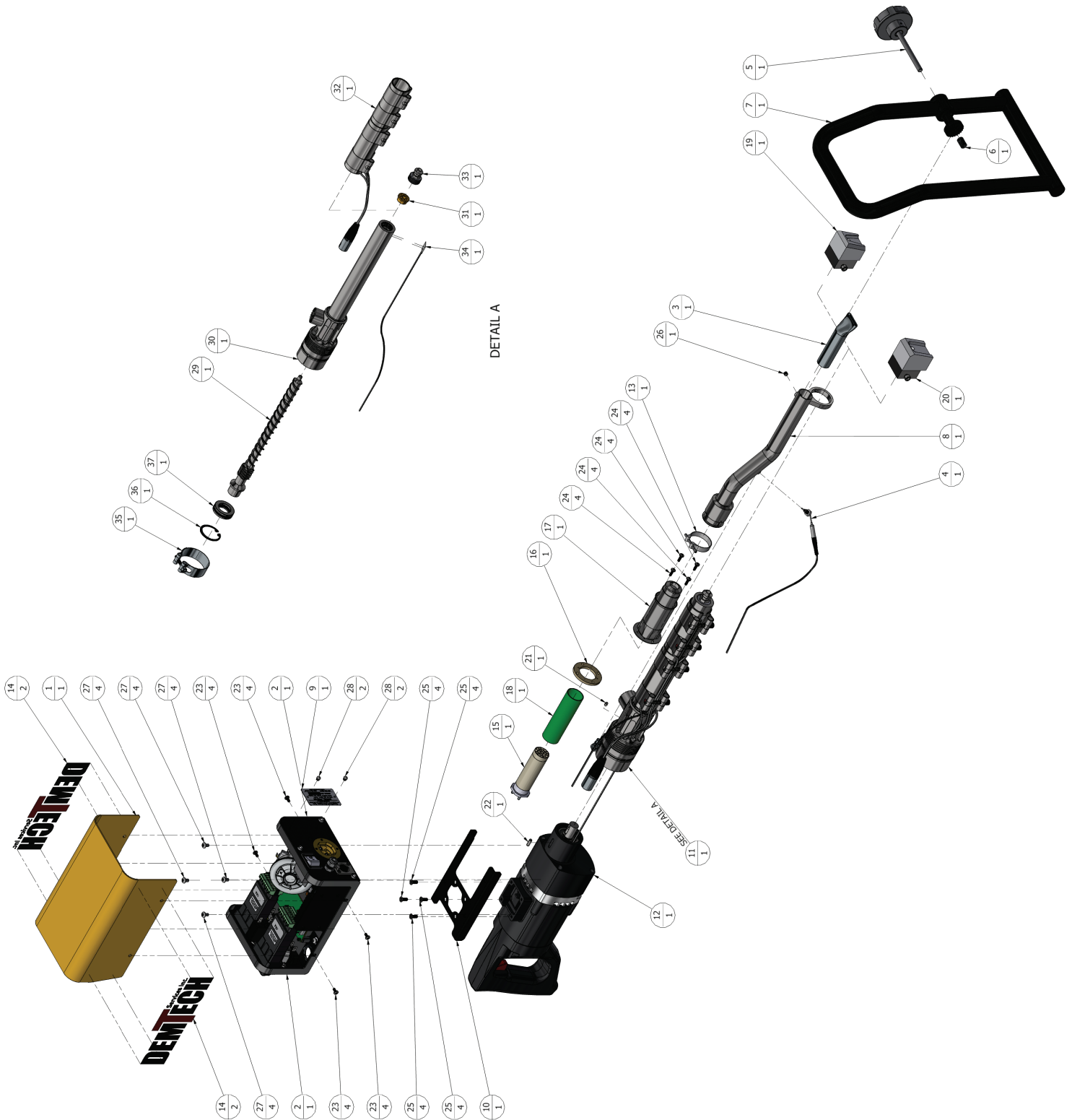

1.1 600-0105/A – ASSY, PRO-X5 EXTRUSION WELDER (Parts ID)

PARTS LIST			
REF. NO	PART NUMBER	DESCRIPTION	QTY
1	600-056	COVER, CONTROLLER HOUSING, X5	1
2	600-100/X5/A	ASSEMBLY, CONTROLLER, PRO-X5	1
3	600-13	NOZZLE, PRE-HEAT MANIFOLD	1
4	600-21/X5	ASSEMBLY, THERMOCOUPLE	1
5	600-22.0/X4	ASSEMBLY, HANDLE STAND KNOB	1
6	600-22.2	SPRING, STANDLE	1
7	600-27/X4/A	ASSEMBLY, ADJUSTABLE HANDLE STAND	1
8	600-38/X4	MANIFOLD, EXTRUDER, PRE-HEAT, WELDMENT	1
9	600-399/X5	PLATE, SERIAL, PRO-X5	1
10	600-64/X4	BRACKET, CONTROLLER HOUSING	1
11	600-BARREL/X5/A	ASSEMBLY, BARREL COMPLETE, PRO-X	1
12	600-DRILL/X5/A	ASSEMBLY, DRILL MOTOR COMPLETE, PRO-X5	1
13	605-058	CLAMP, SCREW, 30-36mm RANGE, STAINLESS STEEL	1
14	LABEL-DEMTECH	LABEL, DEMTECH, LARGE	2
15	L-100.699	ELEMENT, HEAT, 230V, 1550 WATTS	1
16	L-103.224	RING, FIBER	1
17	PRT-75054	SLEEVE, HEAT, SMALL	1
18	PRT-75056	TUBE, MICA, INSULATION, SMALL HEATER	1
19	TS-600-60-AEG/A	ASSEMBLY, SHOE, OVERLAP, NARROW FOR 1.0-2.0mm (40-80mil) SHEET THICKNESS	1
20	TS-600-60/A	ASSEMBLY, SHOE, OVERLAP FOR 1.0-2.0mm (40-80mil) SHEET THICKNESS	1
21	NS-HARDWARE	PIN, DOWEL, 3/16" OD X 1/4" LONG, 18-8 STAINLESS STEEL	1
22	NS-HARDWARE	PIN, DOWEL, 3/16" OD X 1/2" LONG, 18-8 STAINLESS STEEL	1
23	NS-HARDWARE	SCREW, M4 X 0.7 X 8mm LONG, PAN HEAD PHILLIPS, 18-8 STAINLESS STEEL	4
24	NS-HARDWARE	SCREW, M4 X 0.7 X 12mm LONG, PAN HEAD PHILLIPS, 18-8 STAINLESS STEEL	4
25	NS-HARDWARE	SCREW, M5 X 0.8 X 12mm LONG, FLAT HEAD PHILLIPS, 18-8 STAINLESS STEEL	4
26	NS-HARDWARE	SCREW, SET, M6 X 1 X 6mm LONG, CUP POINT ALLEN, 18-8 STAINLESS STEEL	1
27	NS-HARDWARE	SCREW, M5 X 0.8 X 8mm LONG, BUTTON HEAD SOCKET CAP, 18-8 STAINLESS STEEL	4
28	NS-HARDWARE	RIVET, 1/8" BLIND, DOMED HEAD, .063-.125" MATL THICK, 18-8 STAINLESS STEEL	2
29	600-01A-440C	SCREW, EXTRUSION, PRO-X	1
30	600-02	BARREL, EXTRUDER, POST-WELD	1
31	600-02B.1/BR	MIXING PLUG, BRONZE	1
32	600-03EX/A	ASSEMBLY, HEAT BAND, PRO-X, W/ PLUG	1
33	600-20	NOZZLE, BARREL OUTPUT, X2	1
34	600-23/X4	ASSEMBLY, THERMOCOUPLE	1
35	600-31	CLAMP, BARREL	1
36	600-50	SNAP RING, THRUST BEARING & DRIVE SHAFT	1
37	600-D20	BEARING, THRUST	1

***1.2 600-0105/A – ASSY, PRO-X5 EXTRUSION WELDER
(Parts List)***

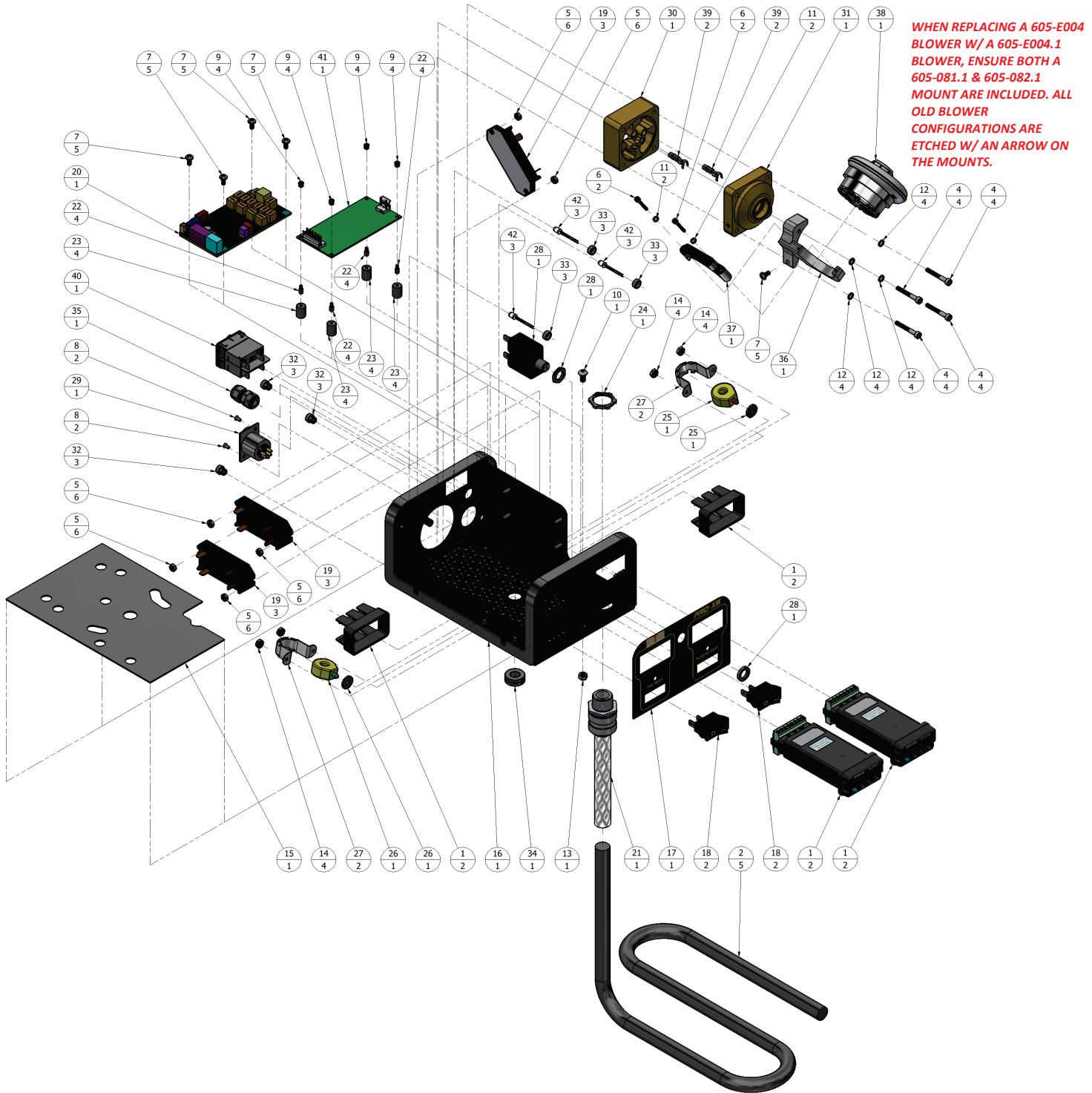

**1.3 600-100/X5/A – ASSY, CONTROLLER, PRO-X5
(Parts ID)**

PARTS LIST			
REF. NO	PART NO	DESCRIPTION	QTY
1	100-426	CONTROLLER, TEMPERATURE, EZ-ZONE	2
2	100-475	CABLE, POWER CORD (ASSEMBLY, 600-CORD/X5/A)	5
3	600-055	HOUSING, CONTROLLER, X5	1
4	600-055.03	SCREW, M4 X 0.7 X 30mm LONG, SOCKET HEAD CAP, 18-8 STAINLESS STEEL	4
5	600-055.04	NUT, M4 X 0.7 HEX, 7mm WIDE X 3.2mm THICK, 18-8 STAINLESS STEEL	6
6	600-055.05	SCREW, M3 X 0.5 X 22mm LONG, SOCKET HEAD CAP, 18-8 STAINLESS STEEL	2
7	600-055.06	SCREW, M4 X 0.7 X 8mm LONG, PAN HEAD PHILLIPS, 18-8 STAINLESS STEEL	5
8	600-055.07	SCREW, M3 X 0.5 X 6mm LONG, FLAT HEAD PHILLIPS, 18-8 STAINLESS STEEL	2
9	600-055.08	NUT, ALLEN, 4-40 X .18" LONG, ALLOY STEEL	4
10	600-055.09	SCREW, M5 X 0.8 X 10mm LONG, BUTTON HEAD SOCKET CAP, 18-8 STAINLESS STEEL	1
11	600-055.10	WASHER, M3 REGULAR SPLIT LOCK, 18-8 STAINLESS STEEL	2
12	600-055.12	WASHER, M4 REGULAR SPLIT LOCK, 18-8 STAINLESS STEEL	4
13	600-055.13	NUT, M5 X 0.8 HEX, NYLON-INSERT LOCKNUT, 18-8 STAINLESS STEEL	1
14	600-055.14	NUT, 6-32 HEX W/ TOOTH WASHER, 5/16" WIDE X 7/64" THICK, 18-8 STAINLESS STEEL	4
15	600-055F	FILTER, CONTROLLER HOUSING, X5	1
16	600-055G	GASKET, CONTROLLER HOUSING, X5	1
17	600-057	OVERLAY, CONTROL PANEL, X5	1
18	600-06	SWITCH, PRE-HEAT / PLASTIC HEAT	2
19	600-060	RELAY, SOLID STATE, 24-280 VAC, DC INPUT, 25 AMP	3
20	600-061	ASSEMBLY, CONTROLLER INTERCONNECT PCB	1
21	600-062	STRAIN RELIEF, 1/2" MNPT STRAIGHT X .50-.63" DIA CORD, ALUMINUM	1
22	600-063	THREAD ADAPTER, 8-32 MALE TO 4-40 MALE, STAINLESS STEEL	4
23	600-064	MOUNT, VIBRATION-DAMPING SANDWICH, 8-32 FEMALE X 8-32 FEMALE	4
24	600-065	NUT, CONDUIT FITTING LOCK, 1/2" NPT, ZINC PLATED STEEL	1
25	600-09	CURRENT INDICATOR, RED	1
26	600-10	CURRENT INDICATOR, GREEN	1
27	600-11	BRACKET, CURRENT INDICATOR	2
28	600-29EX	CIRCUIT BREAKER, 5A	1
29	600-41EX	RECEPTACLE, HEATBAND, 5 PRONG	1
30	605-051	MOUNT, HEATER, INTERNAL	1
31	605-060	HOUSING, BLOWER, INTERNAL	1
32	605-071	CLIP, LED, 5mm, W/ BEZEL	3
33	605-072	SPACER, LED, 5mm	3
34	605-073	GROMMET, 3/4" ID X 1-3/8" OD X 1/16" PANEL THK X 1-1/16" DIA PANEL HOLE, BUNA-N	1
35	605-074	CORDGRIP, LIQUID TIGHT, STRAIGHT-THRU, PG HUB, BLACK	1
36	605-081.1	BRACKET, BLOWER MOUNT, TYPE 2	1
37	605-082.1	CLAMP, BLOWER MOUNT, TYPE 2	1
38	605-E004.1	BLOWER, MINIATURE RADIAL, 70 X 45.7mm, 24 VDC	1
39	605-E007	CONTACT, 4mm DIA, DUAL CRIMP	2
40	605-E009	SWITCH, POWER/BREAKER, DPST, ON/OFF, 15A @ 240 VAC, WHITE OPAQUE	1
41	605-E010	POWER SUPPLY, DUAL OUTPUT, +5VDC @ 3.5A / +24VDC @ 1.5A	1
42	605-E011	LED, HIGH INTENSITY, 5mm, 15 DEGREE VIEWING ANGLE, WHITE	3

**1.4 600-100/X5/A – ASSY, CONTROLLER, PRO-X5
(Parts List)**

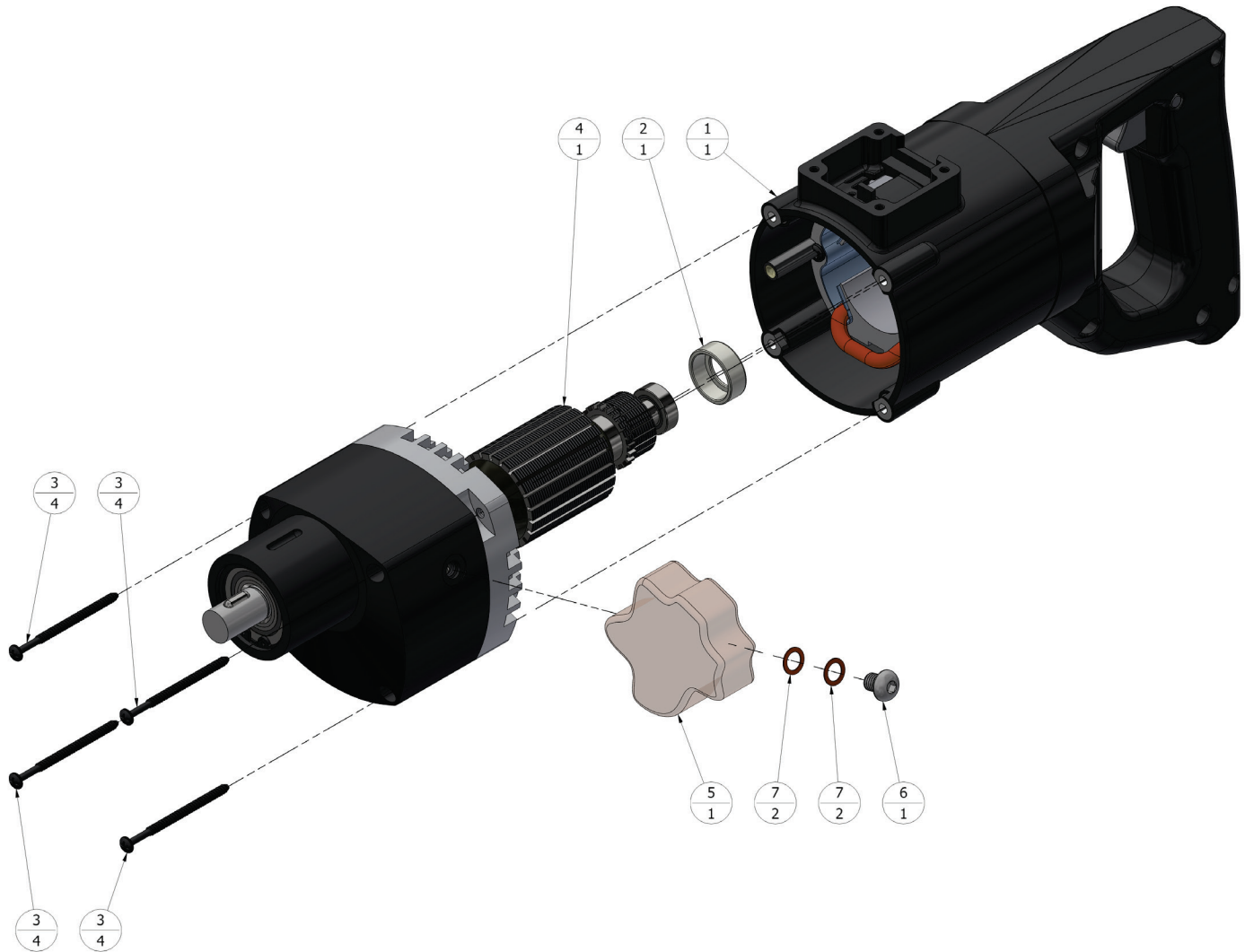

**1.5 600-DRILL/X5/A – ASSY, DRILL MOTOR COMPLETE, PRO-X5
(Parts ID)**

PARTS LIST			
REF. NO	PART NUMBER	DESCRIPTION	QTY
1	600-D08/X5/A	ASSEMBLY, MOTOR HOUSING COMPLETE, PRO-X5	1
2	600-D23	SEAT, ARMATURE BEARING, CUP	1
3	600-D24.1EX	SCREW, GEAR HOUSING	4
4	600-D100A/X5/A	ASSEMBLY, GEAR BOX COMPLETE, W/ ARMATURE, CODE: RED	1
5	600-OIL	OIL, GEAR, 75W90, 5 OZ. VOLUME	1
6	NS-HARDWARE	SCREW, M8 X 1.25 X 10mm LONG, BUTTON HEAD CAP, 18-8 STAINLESS STEEL	1
7	NS-HARDWARE	WASHER, .328" ID X .482" OD X .020" THICK, COPPER	2

***1.6 600-DRILL/X5/A – ASSY, DRILL MOTOR COMPLETE, PRO-X5
(Parts List)***



**1.7 600-D08/X5/A – ASSY, MOTOR HOUSING COMPLETE
(Parts ID)**

PARTS LIST			
REF. NO	PART NUMBER	DESCRIPTION	QTY
1	600-D03	HOLDER, BRUSH	2
2	600-D04	INSULATOR, BRUSH	2
3	600-D05	BRUSH, DRILL MOTOR	2
4	600-D06	KIT, "D" HANDLE (RIGHT)	1
5	600-D06	KIT, "D" HANDLE (LEFT)	1
6	600-D07	SWITCH, TRIGGER	1
7	600-D08	HOUSING, MOTOR	1
8	600-D22/S	SLEEVING, FIELD WINDING WIRES, 3.5" LONG	1
9	600-D22/X4	FIELD COIL, 230V, STYLE "B", CODE: RED	1
10	600-D24.1EX	SCREW, GEAR HOUSING	2
11	600-D30	PLUG, "D" HANDLE	1
12	NS-HARDWARE	SCREW, #10 X 3/8" LONG, PAN HEAD PHILLIPS, HIGH-LOW, ZINC PLATED STEEL	4
13	NS-HARDWARE	SCREW, #10 X 1/2" LONG, PAN HEAD PHILLIPS, HIGH-LOW, ZINC PLATED STEEL	2
14	NS-HARDWARE	SCREW, #10 X 3/4" LONG, PAN HEAD PHILLIPS, HIGH-LOW, ZINC PLATED STEEL	9

**1.8 600-D08/X5/A – ASSY, MOTOR HOUSING COMPLETE
(Parts List)**

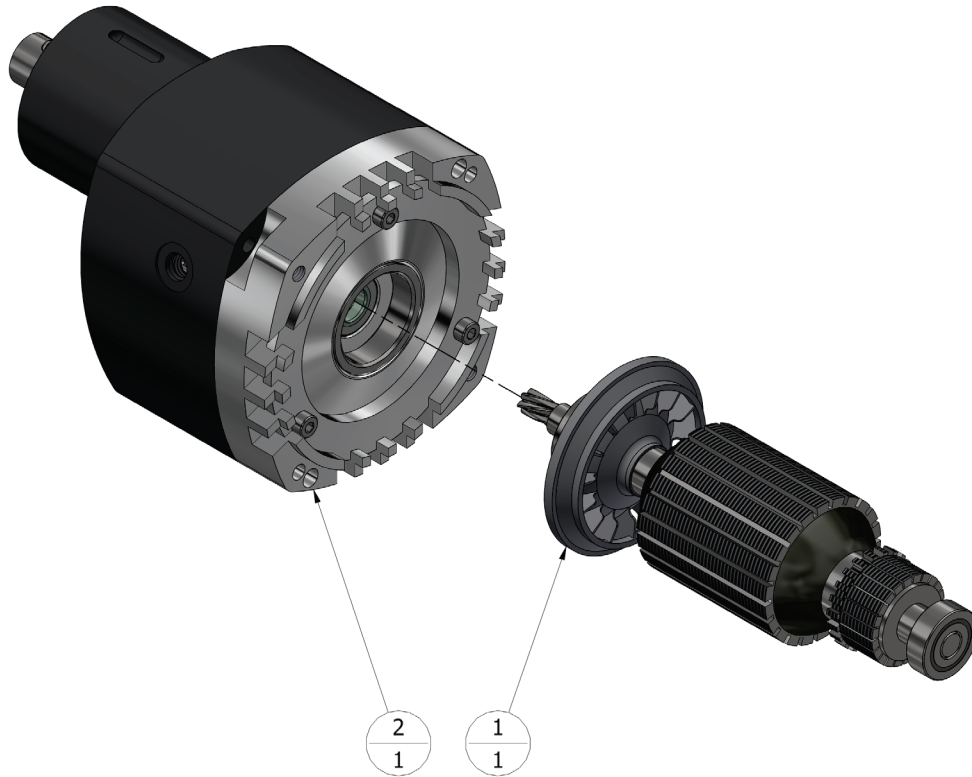

**1.9 600-D100A/X5/A - ASSY, GEAR BOX COMPLETE, W/
ARMATURE, CODE: RED, PRO-X5 (Parts ID)**

PARTS LIST			
REF. NO	PART NUMBER	DESCRIPTION	QTY
1	600-D02/X5/A	ASSEMBLY, MOTOR ARMATURE / BEARING / FAN, CODE: WHITE	1
2	600-D100/X4/A	ASSEMBLY, GEAR BOX COMPLETE, W/O ARMATURE	1

***1.10 600-D100A/X5/A - ASSY, GEAR BOX COMPLETE, W/
ARMATURE, CODE: RED, PRO-X5 (Parts List)***

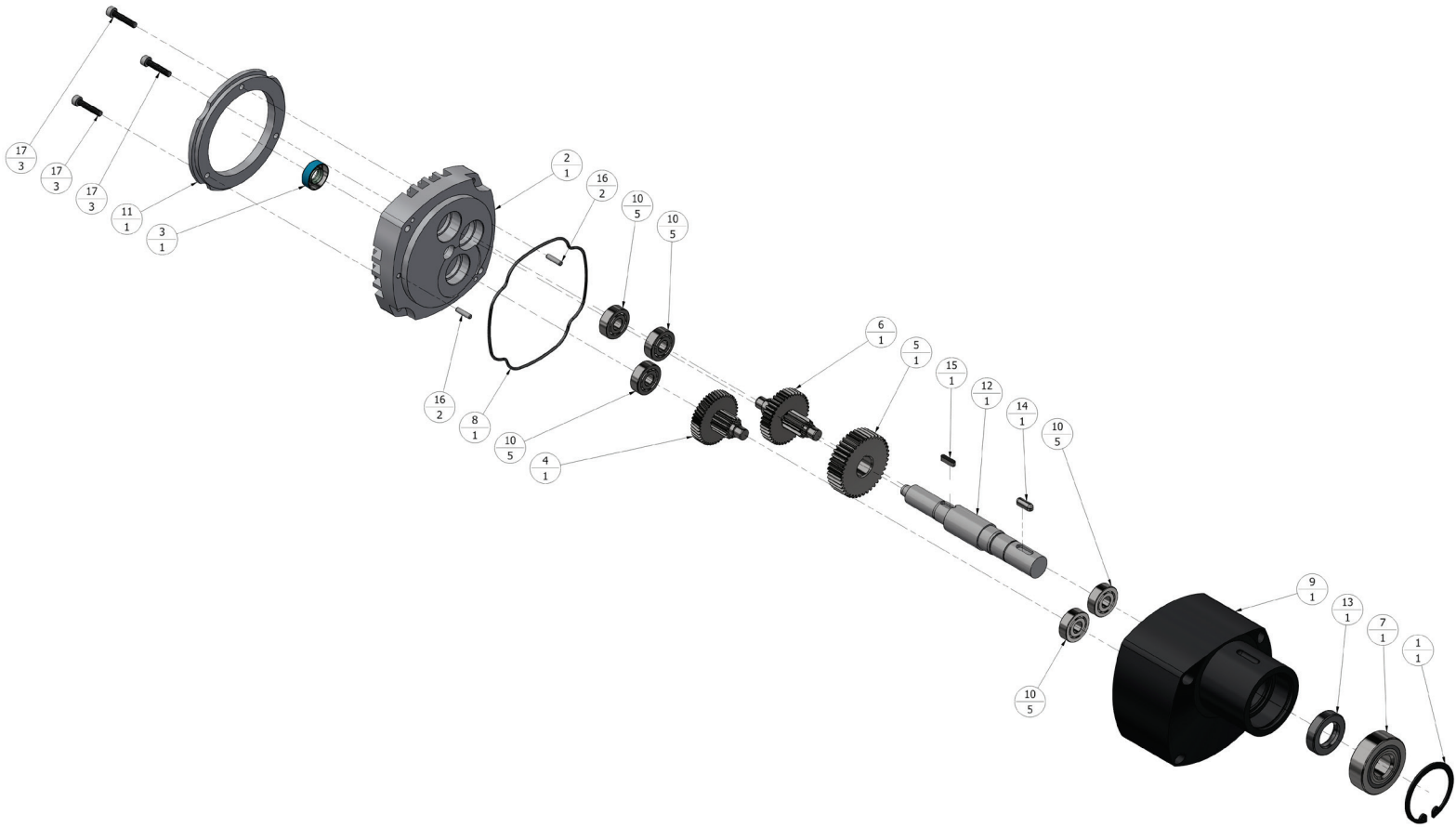

***1.11 600-D100/X4/A – ASSY, GEARBOX COMPLETE, W/O
ARMATURE (Parts ID)***

PARTS LIST			
REF. NO	PART NUMBER	DESCRIPTION	QTY
1	600-50	SNAP RING, THRUST BEARING & DRIVE SHAFT	1
2	600-D01EX	PLATE, GEAR CASING, BEARING	1
3	600-D02/S	SEAL, ARMATURE	1
4	600-D11	ASSEMBLY, PINION / HELICAL GEAR SET	1
5	600-D12	GEAR, DRIVE SHAFT, LARGE	1
6	600-D15	ASSEMBLY, PINION / SPUR GEAR SET	1
7	600-D17	BEARING, DRIVE SHAFT	1
8	600-D24/O	O-RING, GEARBOX	1
9	600-D24EX	CASING, DRILL MOTOR, GEAR	1
10	600-D25	BEARING, GEARBOX	5
11	600-D26	DISC, BEARING PLATE, VENTILATION	1
12	600-D30.0	SHAFT, DRIVE	1
13	600-D30/S/X4	SEAL, OUTPUT SHAFT, GEAR BOX, PRO-X4	1
14	600-D31EX	KEY, OUTPUT SHAFT TO EXTRUSION SCREW	1
15	600-D31K	KEY, LARGE GEAR TO OUTPUT SHAFT	1
16	NS-HARDWARE	PIN, DOWEL, 1/8" OD X 1/2" LONG, 18-8 STAINLESS STEEL	2
17	NS-HARDWARE	SCREW, M4 X 0.7 X 20mm LONG, SOCKET HEAD CAP, 18-8 STAINLESS STEEL	3

***1.12 600-D100/X4/A – ASSY, GEARBOX COMPLETE, W/O
ARMATURE (Parts List)***